

LETTER OF SUBMITTAL AND ATTACHMENTS



A DESIGN-BUILD PROJECT

I-95 Safety Improvements at Route 3

From: 0.115 Miles South of Int. Route 3 To: 1.220 Miles North of Int. Route 3
City of Fredericksburg, Virginia

Submitted to:
Virginia Department of Transportation



State Project No.: 0095-111-278
Federal Project No.: OC-095-2(535)
Contract ID Number: C00107715DB91

SOLICITATION DB 107715B

Submitted by:
Branscome Incorporated
in association with Rinker Design Associates, P.C.



January 4, 2017

ATTACHMENT 4.0.1.1
I-95 Safety Improvements at Route 3
LETTER OF SUBMITTAL CHECKLIST AND CONTENTS

Offerors shall furnish a copy of this Letter of Submittal Checklist, with the page references added, with the Letter of Submittal.

Letter of Submittal Component	Form (if any)	RFP Part 1 Cross Reference	Page Reference
Letter of Submittal Checklist and Contents	Attachment 4.0.1.1	Section 4.0.1.1	i-ii
Acknowledgement of RFP, Revisions, and/or Addenda	Attachment 3.4 (Form C-78-RFP)	Sections 3.4; 4.0.1.1	iii
Letter of Submittal	NA	Sections 4.1	
Letter of Submittal on Offeror's letterhead	NA	Section 4.1.1	1
Offeror's full legal name and address	NA	Section 4.1.1	1
Authorized representative's original signature	NA	Section 4.1.1	2
Declaration of intent	NA	Section 4.1.2	1
120 day declaration	NA	Section 4.1.3	1
Point of Contact information	NA	Section 4.1.4	1
Principal Officer information	NA	Section 4.1.5	1
Offeror's Corporate Structure	NA	Section 4.1.6	2
Full Legal Name of Lead Contractor, Lead Designer, and QAM	NA	Section 4.1.7	2
Offeror's VDOT prequalification information	NA	Section 4.1.8	2
DBE statement confirming Offeror is committed to achieving the required DBE goal	NA	Section 4.1.9	2
Final Completion Date	NA	Section 4.1.10	2

ATTACHMENT 4.0.1.1

I-95 Safety Improvements at Route 3

LETTER OF SUBMITTAL CHECKLIST AND CONTENTS

Letter of Submittal Component	Form (if any)	RFP Part 1 Cross Reference	Page Reference
Attachments to the Letter of Submittal	NA	Section 4.2	
Affiliated and/ or Subsidiary Companies	Attachment 4.2.1	Section 4.2.1	3
Certification Regarding Debarment Forms	Attachment 4.2.2(a) Attachment 4.2.2(b)	Section 4.2.2	4 5-7
Offeror's VDOT prequalification information	NA	Section 4.2.3	8
Evidence of obtaining bonding	NA	Section 4.2.4	9-10
Full size copies of DPOR licenses and SCC registrations	NA	Section 4.2.5	11-15
SCC registration information - businesses	Attachment 4.2.5	Section 4.2.5.1	16
DPOR registration information - businesses	Attachment 4.2.5	Section 4.2.5.2	16
Lead Contractor Work History Form	Attachment 4.2.6(a)	Section 4.2.6	17-19
Lead Designer Work History Form	Attachment 4.2.6(b)	Section 4.2.6	20-22
Conceptual Roadway Plans	NA	Section 4.2.7	23-39

ATTACHMENT 3.6**COMMONWEALTH OF VIRGINIA
DEPARTMENT OF TRANSPORTATION**

RFP NO. C00107715DB91
 PROJECT NO.: 0095-111-278, P101, C201, C501

ACKNOWLEDGEMENT OF RFP, REVISION AND/OR ADDENDA

Acknowledgement shall be made of receipt of the Request for Proposals (RFP) and/or any and all revisions and/or addenda pertaining to the above designated project which are issued by the Department prior to the Letter of Submittal submission date shown herein. Failure to include this acknowledgement in the Letter of Submittal may result in the rejection of your proposal.

By signing this Attachment 3.6, the Offeror acknowledges receipt of the RFP and/or following revisions and/or addenda to the RFP for the above designated project which were issued under cover letter(s) of the date(s) shown hereon:

1. Cover letter of RFP – September 27, 2016
(Date)
2. Cover letter of RFP Addendum #1 – October 14, 2016
(Date)
3. Cover letter of RFP Addendum #2 – November 10, 2016
(Date)
4. Cover letter of RFP Addendum #3 – December 02, 2016
(Date)
5. Cover letter of RFP Addendum #4 – December 05, 2016
(Date)
6. Cover letter of RFP Addendum #5 – December 14, 2016
(Date)



 SIGNATURE

1/3/2017

 DATE

Branscome Incorporated

 PRINTED NAME

Assistant Regional Manager

 TITLE

January 4, 2017



Stephen D. Kindy, P.E.
Alternative Project Delivery Division
Virginia Department of Transportation
1401 East Broad Street
Annex Building, 8th Floor
Richmond, Virginia 23219

www.branscome.com

Re: I-95 Safety Improvements at Route 3, Project No. 0095-111-278

Dear Mr. Kindy:

Branscome Incorporated (Branscome) is pleased to present our Letter of Submittal for the above referenced Design-Build (DB) project to the Virginia Department of Transportation (VDOT). Our response contains all information requested in the Request for Proposals (RFP) and subsequent Addenda.

4.1 Letter of Submittal

4.1.1 Offeror's Full Legal Name and Address and Authorized Representative:

Branscome Incorporated is the Offeror and legal entity that will execute this contract with VDOT. **J. Parker Mills** is the authorized representative and Point Of Contact for the Branscome Team for all matters associated with this Project. Our full legal name and address are as follows:

Branscome Incorporated
432 McLaws Circle
Williamsburg, VA 23185

432 MCLAWS CIRCLE
WILLIAMSBURG, VIRGINIA 23185

PHONE: 757-229-2504

FAX: 757-220-0390

4.1.2 Declaration of Intent: Branscome Incorporated (Branscome), if selected, will enter into a contract with VDOT for the Project in accordance with the terms of the RFP.

4.1.3 120-Day Declaration: Pursuant to Part 1, Section 8.2, Branscome declares that the offer represented by our Price Proposal will remain in full force and effect for one hundred twenty (120) days after January 4, 2017, the date the Proposal is submitted to VDOT.

4.1.4 Point of Contact Information:

J. Parker Mills, Assistant Regional Manager
432 McLaws Circle
Williamsburg, VA 23185
Phone Number: (757) 229-2504
Fax Number: (757) 220-0390
Email Address: millsp@branscome.com

4.1.5 Principal Officer Information:

W. Stuart Patterson, Jr., President
432 McLaws Circle
Williamsburg, VA 23185
Phone Number: (757) 229-2504



4.1.6 Offeror's Corporate Structure: Branscome Incorporated is an active, registered Corporation (SCC Corp ID: 05506134) in Virginia and will take financial responsibility for this project. A single 100% performance bond and payment bond will be provided for the total contract value and time period. There are no liability limitations on behalf of Branscome Incorporated.

4.1.7 Full Legal Name of Lead Contractor, Lead Designer, and QAM:

Lead Contractor: **Branscome Incorporated**, the Offeror, will serve as the prime/general contractor responsible for overall construction of the Project and will serve as the legal entity who will execute the Contract with VDOT.

www.branscome.com

Lead Designer: **Rinker Design Associates, P.C. (RDA)** is the prime design consulting firm responsible for the overall design of this Project.

QAM: **Rinker Design Associates, P.C. (RDA)** is also the QAM firm who will provide the Quality Assurance Manager for this Project.

4.1.8 Offeror's VDOT Prequalification Information: Branscome Incorporated prequalification (No. B850) is active and in good standing as outlined in VDOT's Rules Governing Prequalification Privileges. An 8.5"x11" copy of our VDOT Prequalification Certificate is provided in the Attachments to the Letter of Submittal.

432 MCLAWS CIRCLE
WILLIAMSBURG, VIRGINIA 23185
PHONE: 757-229-2504
FAX: 757-220-0390

4.1.9 DBE Statement: Branscome Incorporated supports the Disadvantaged Business Enterprise (DBE) program and is committed to achieving the fourteen percent (14%) DBE participation goal for the entire value of this contract utilizing Virginia-certified DBE firms. Branscome will take all necessary steps to ensure that DBE firms have the maximum opportunity to compete for and perform services on this DB contract.

4.1.10 Final Completion Date: In accordance with RFP Part 1, Section 2.3.1, Branscome proposes a Final Completion Date of January 11, 2019.

We thank you for the opportunity to submit our Letter of Submittal. We are confident that our Team will deliver this project for VDOT and project stakeholders in a high quality, timely, and economical manner.

Sincerely,

J. Parker Mills, Assistant Regional Manager
Branscome Incorporated

4.2 Attachments to the Letter of Submittal

4.2.1 Affiliated and/or Subsidiary Companies

4.2.2 Certification Regarding Debarment Forms

ATTACHMENT 4.2.2(a)
CERTIFICATION REGARDING DEBARMENT
PRIMARY COVERED TRANSACTIONS

Project No.: 0095-111-278

1) The prospective primary participant certifies to the best of its knowledge and belief, that it and its principals:

a) Are not presently debarred, suspended, proposed for debarment, declared ineligible, or voluntarily excluded from covered transactions by any Federal department or agency.

b) Have not within a three-year period preceding this proposal been convicted of or had a civil judgment rendered against them for commission of fraud or a criminal offense in connection with obtaining, attempting to obtain, or performing a public (Federal, State or local) transaction or contract under a public transaction; and have not been convicted of any violations of Federal or State antitrust statutes or commission of embezzlement, theft, forgery, bribery, falsification, or destruction of records, making false statements, or receiving stolen property;

c) Are not presently indicted for or otherwise criminally or civilly charged by a governmental entity (Federal, State or local) with commission of any of the offenses enumerated in paragraph 1) b) of this certification; and

d) Have not within a three-year period preceding this application/proposal had one or more public transactions (Federal, State or local) terminated for cause or default.

2) Where the prospective primary participant is unable to certify to any of the statements in this certification, such prospective participant shall attach an explanation to this proposal.

The undersigned makes the foregoing statements to be filed with the proposal submitted on behalf of the Offeror for contracts to be let by the Commonwealth Transportation Board.

	1/3/2017	Assistant Regional Manager
Signature	Date	Title

Branscome Incorporated
Name of Firm

ATTACHMENT 4.2.2(b)
CERTIFICATION REGARDING DEBARMENT
LOWER TIER COVERED TRANSACTIONS

Project No.: 0095-111-278

- 1) The prospective lower tier participant certifies, by submission of this proposal, that neither it nor its principals is presently debarred, suspended, proposed for debarment, declared ineligible, or voluntarily excluded from participation in this transaction by any Federal department or agency.

- 2) Where the prospective lower tier participant is unable to certify to any of the statements in this certification, such prospective participant shall attach an explanation to this proposal.

The undersigned makes the foregoing statements to be filed with the proposal submitted on behalf of the Offeror for contracts to be let by the Commonwealth Transportation Board.



Signature Date

Executive Director of DB Services /
Title General Manager / Principal

Rinker Design Associates, P.C.

Name of Firm

ATTACHMENT 4.2.2(b)
CERTIFICATION REGARDING DEBARMENT
LOWER TIER COVERED TRANSACTIONS

Project No.: 0095-111-278

- 1) The prospective lower tier participant certifies, by submission of this proposal, that neither it nor its principals is presently debarred, suspended, proposed for debarment, declared ineligible, or voluntarily excluded from participation in this transaction by any Federal department or agency.

- 2) Where the prospective lower tier participant is unable to certify to any of the statements in this certification, such prospective participant shall attach an explanation to this proposal.

The undersigned makes the foregoing statements to be filed with the proposal submitted on behalf of the Offeror for contracts to be let by the Commonwealth Transportation Board.

 10/31/2016
Signature Date

Vice President
Title

EEE Consulting, Inc.
Name of Firm

ATTACHMENT 4.2.2(b)
CERTIFICATION REGARDING DEBARMENT
LOWER TIER COVERED TRANSACTIONS

Project No.: 0095-111-278

- 1) The prospective lower tier participant certifies, by submission of this proposal, that neither it nor its principals is presently debarred, suspended, proposed for debarment, declared ineligible, or voluntarily excluded from participation in this transaction by any Federal department or agency.
- 2) Where the prospective lower tier participant is unable to certify to any of the statements in this certification, such prospective participant shall attach an explanation to this proposal.

The undersigned makes the foregoing statements to be filed with the proposal submitted on behalf of the Offeror for contracts to be let by the Commonwealth Transportation Board.

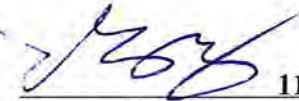

Signature

11/2/2016

Date

Vice President

Title

DMY Engineering Consultants Inc.

Name of Firm



COMMONWEALTH OF VIRGINIA



CERTIFICATE OF QUALIFICATION

BRANSCOME INC.

Vendor Number: **B850**

In accordance with the Regulations of the Virginia Department of Transportation, your firm is hereby notified that the following Rating has been assigned to your firm:

PREQUALIFIED

Your firm specializes in the noted Classification(s):

**GRADING; ASPHALT CONCRETE PAVING; CLEARING AND GRUBBING;
ROADWAY MILLING; UNDERGROUND UTILITIES**

Issue Date: February 29, 2016

This Rating and Classification will Expire: February 28, 2017

Suzanne FR Lucas, State Prequalification Officer

Don E. Silies, Director of Contracts

It is not permissible to alter this document, use after posted expiration date, or use by persons or firms other than those named on this certificate.



Liberty Mutual Surety

8044 Montgomery Road, Suite 150
Cincinnati, Ohio 45236

January 4, 2017

Commonwealth of Virginia, Department of Transportation
1401 East Broad Street
Richmond, Virginia 23146

RE: Branscome, Inc.
Project No: 0095-111-278
Project Name: I-95 Safety Improvements at Route 3

Dear Gentlemen/Ladies:

As surety for Branscome, Inc., Liberty Mutual Insurance Company with A.M. Best Financial Strength Rating A (Excellent) and Financial Size Category XV (\$2 Billion or Greater) and Fidelity and Deposit Company of Maryland with A.M. Best Financial Strength Rating A+ (Superior) and Financial Size Category XV (\$2 Billion or Greater) is capable of obtaining 100% Performance Bond and 100% Labor and Materials Payment Bond in the amount of the anticipated cost of construction, and said bonds will cover the Project and any warranty periods as provided for in the Contract Documents on behalf of the Contractor, in the event that such firm be the successful bidder and enter into a contract for this Project.

We have approved bonds for their projects in excess of \$50,000,000.00, with an aggregate bonding capacity of \$750,000,000. The approval for all bonds is contingent upon the review and acceptability of the underwriting terms at the time of the request by the Principal and bond forms acceptable to the Principal and Surety and written evidence that adequate financing has been made available for this project.

It is understood, that any arrangement for the performance and payment bonds is a matter between Branscome, Inc. and ourselves, and we reserve the right to perform normal underwriting at the time of the final bond request, to include, but not limited to the acceptability of the project contract documents, bond forms and financing. We assume no liability to third parties or to you if for any reason we do not execute the said bonds.

Should you have any questions, please do not hesitate to call.

Very truly yours,

LIBERTY MUTUAL INSURANCE COMPANY & FIDELITY AND DEPOSIT COMPANY OF MARYLAND

WENDY LEE WADKINS
ATTORNEY-IN-FACT

Attached

cc: Mr. Ed Smith
Branscome, Inc.

Ms. Kelley Brown
Liberty Mutual Insurance Company

Mr. Paul McCarthy
Zurich NA

THIS POWER OF ATTORNEY IS NOT VALID UNLESS IT IS PRINTED ON RED BACKGROUND.

This Power of Attorney limits the acts of those named herein, and they have no authority to bind the Company except in the manner and to the extent herein stated.

Certificate No. 7381386

American Fire and Casualty Company
The Ohio Casualty Insurance Company

Liberty Mutual Insurance Company
West American Insurance Company

POWER OF ATTORNEY

KNOWN ALL PERSONS BY THESE PRESENTS: That American Fire & Casualty Company and The Ohio Casualty Insurance Company are corporations duly organized under the laws of the State of New Hampshire, that Liberty Mutual Insurance Company is a corporation duly organized under the laws of the State of Massachusetts, and West American Insurance Company is a corporation duly organized under the laws of the State of Indiana (herein collectively called the "Companies"), pursuant to and by authority herein set forth, does hereby name, constitute and appoint, Charles N. Parsons; Christopher F. Mulvaney; Mark A. Lynch; Pablo Rios, Jr.; Vincent J. Mancini; Wendy Lee Wadkins

all of the city of Radnor, state of PA each individually if there be more than one named, its true and lawful attorney-in-fact to make, execute, seal, acknowledge and deliver, for and on its behalf as surety and as its act and deed, any and all undertakings, bonds, recognizances and other surety obligations, in pursuance of these presents and shall be as binding upon the Companies as if they have been duly signed by the president and attested by the secretary of the Companies in their own proper persons.

IN WITNESS WHEREOF, this Power of Attorney has been subscribed by an authorized officer or official of the Companies and the corporate seals of the Companies have been affixed thereto this 27th day of May, 2016



American Fire and Casualty Company
The Ohio Casualty Insurance Company
Liberty Mutual Insurance Company
West American Insurance Company

By: David M. Carey
David M. Carey, Assistant Secretary

STATE OF PENNSYLVANIA ss
COUNTY OF MONTGOMERY

On this 27th day of May, 2016, before me personally appeared David M. Carey, who acknowledged himself to be the Assistant Secretary of American Fire and Casualty Company, Liberty Mutual Insurance Company, The Ohio Casualty Insurance Company, and West American Insurance Company, and that he, as such, being authorized so to do, execute the foregoing instrument for the purposes therein contained by signing on behalf of the corporations by himself as a duly authorized officer.

IN WITNESS WHEREOF, I have hereunto subscribed my name and affixed my notarial seal at Plymouth Meeting, Pennsylvania, on the day and year first above written.



Notarial Seal
Teresa Pastella, Notary Public
Plymouth Twp., Montgomery County
My Commission Expires March 28, 2017
Member, Pennsylvania Association of Notaries

By: Teresa Pastella
Teresa Pastella, Notary Public

This Power of Attorney is made and executed pursuant to and by authority of the following By-laws and Authorizations of American Fire and Casualty Company, The Ohio Casualty Insurance Company, Liberty Mutual Insurance Company, and West American Insurance Company which resolutions are now in full force and effect reading as follows:

ARTICLE IV – OFFICERS – Section 12. Power of Attorney. Any officer or other official of the Corporation authorized for that purpose in writing by the Chairman or the President, and subject to such limitation as the Chairman or the President may prescribe, shall appoint such attorneys-in-fact, as may be necessary to act in behalf of the Corporation to make, execute, seal, acknowledge and deliver as surety any and all undertakings, bonds, recognizances and other surety obligations. Such attorneys-in-fact, subject to the limitations set forth in their respective powers of attorney, shall have full power to bind the Corporation by their signature and execution of any such instruments and to attach thereto the seal of the Corporation. When so executed, such instruments shall be as binding as if signed by the President and attested to by the Secretary. Any power or authority granted to any representative or attorney-in-fact under the provisions of this article may be revoked at any time by the Board, the Chairman, the President or by the officer or officers granting such power or authority.

ARTICLE XIII – Execution of Contracts – SECTION 5. Surety Bonds and Undertakings. Any officer of the Company authorized for that purpose in writing by the chairman or the president, and subject to such limitations as the chairman or the president may prescribe, shall appoint such attorneys-in-fact, as may be necessary to act in behalf of the Company to make, execute, seal, acknowledge and deliver as surety any and all undertakings, bonds, recognizances and other surety obligations. Such attorneys-in-fact subject to the limitations set forth in their respective powers of attorney, shall have full power to bind the Company by their signature and execution of any such instruments and to attach thereto the seal of the Company. When so executed such instruments shall be as binding as if signed by the president and attested by the secretary.

Certificate of Designation – The President of the Company, acting pursuant to the Bylaws of the Company, authorizes David M. Carey, Assistant Secretary to appoint such attorneys-in-fact as may be necessary to act on behalf of the Company to make, execute, seal, acknowledge and deliver as surety any and all undertakings, bonds, recognizances and other surety obligations.

Authorization – By unanimous consent of the Company's Board of Directors, the Company consents that facsimile or mechanically reproduced signature of any assistant secretary of the Company, wherever appearing upon a certified copy of any power of attorney issued by the Company in connection with surety bonds, shall be valid and binding upon the Company with the same force and effect as though manually affixed.

I, Gregory W. Davenport, the undersigned, Assistant Secretary, of American Fire and Casualty Company, The Ohio Casualty Insurance Company, Liberty Mutual Insurance Company, and West American Insurance Company do hereby certify that the original power of attorney of which the foregoing is a full, true and correct copy of the Power of Attorney executed by said Companies, is in full force and effect and has not been revoked.

IN TESTIMONY WHEREOF, I have hereunto set my hand and affixed the seals of said Companies this 4th day of January, 2017



By: Gregory W. Davenport
Gregory W. Davenport, Assistant Secretary

Not valid for mortgage, note, loan, letter of credit, currency rate, interest rate or residual value guarantees.

To confirm the validity of this Power of Attorney call 1-610-832-8240 between 9:00 am and 4:30 pm EST on any business day.

Lead Contractor

**SCC eFile
Business Entity Details**

BRANSCOME INC.

General

SCC ID: 05506134
Entity Type: Corporation
Jurisdiction of Formation: VA
Date of Formation/Registration: 12/14/2000
Status: Active
Shares Authorized: 1000

Principal Office

432 MCLAWS CIRCLE
WILLIAMSBURG VA23185

Registered Agent/Registered Office

CORPORATION SERVICE COMPANY
Bank of America Center, 16th Floor
1111 East Main Street
RICHMOND VA 23219
RICHMOND CITY 216
Status: Active
Effective Date: 4/29/2011

Select an action

[File a registered agent change](#)
[File a registered office address change](#)
[Resign as registered agent](#)
[File an annual report](#)
[Pay annual registration fee](#)
[Order a certificate of good standing](#)
[Submit a PDF for processing \(What can I submit?\)](#)
[View eFile transaction history](#)
[Manage email notifications](#)

[New Search](#) [Home](#)

SCC eFile
Business Entity Details

Rinker Design Associates, P.C.

General

SCC ID: 02270627
Entity Type: Corporation
Jurisdiction of Formation: VA
Date of Formation/Registration: 2/24/1982
Status: Active
Shares Authorized: 20000

Select an action

- [File a registered agent change](#)
- [File a registered office address change](#)
- [Resign as registered agent](#)
- [File an annual report](#)
- [Pay annual registration fee](#)
- [Order a certificate of good standing](#)
- [Submit a PDF for processing \(What can I submit?\)](#)
- [View eFile transaction history](#)
- [Manage email notifications](#)

Principal Office

9385 DISCOVERY BOULEVARD
SUITE 200
MANASSAS VA20109

New Search

Home

Registered Agent/Registered Office

JOHN S WISIACKAS
ODIN FELDMAN & PITTLEMAN PC
1775 WIEHLE AVENUE STE 400
RESTON VA 20190
FAIRFAX COUNTY 129
Status: Active
Effective Date: 8/27/2012

4.2.5.2 DPOR Registration Documentation

Lead Contractor

EXPIRES ON 02-28-2017	DEPARTMENT OF PROFESSIONAL AND OCCUPATIONAL REGULATION COMMONWEALTH OF VIRGINIA 9960 Mayland Dr., Suite 400, Richmond, VA 23233 Telephone: (804) 367-8500	NUMBER 2705061347
BOARD FOR CONTRACTORS CLASS A CONTRACTOR *CLASSIFICATIONS* H/H		
BRANSCOME INC 432 MCLAWS CIRCLE WILLIAMSBURG, VA 23185		 <i>Jay W. DeBorja</i> The W. DeBorja Director
<small>ALTERATION OF THIS DOCUMENT, USE AFTER EXPIRATION, OR USE BY PERSONS OR FIRMS OTHER THAN THOSE NAMED MAY RESULT IN CRIMINAL PROSECUTION UNDER THE CODE OF VIRGINIA</small>		

COMMONWEALTH of VIRGINIA
Department of Professional and Occupational Regulation
9960 Mayland Drive, Suite 400, Richmond, VA 23233
Telephone: (804) 367-8500

EXPIRES ON
02-28-2018

NUMBER
0410000156

**BOARD FOR ARCHITECTS, PROFESSIONAL ENGINEERS, LAND SURVEYORS, CERTIFIED INTERIOR DESIGNERS
AND LANDSCAPE ARCHITECTS**
PROFESSIONAL CORPORATION BRANCH OFFICE REGISTRATION

PROFESSIONS: ENG, LS



RINKER DESIGN ASSOCIATES PC
927 MAPLE GROVE DR STE 105
FREDERICKSBURG, VA 22407



Jimmy W. DeBoer
Jimmy W. DeBoer, Director

Status can be verified at <http://www.dpor.virginia.gov>

COMMONWEALTH of VIRGINIA
Department of Professional and Occupational Regulation
9960 Mayland Drive, Suite 400, Richmond, VA 23233
Telephone: (804) 367-8500

EXPIRES ON
02-28-2018

NUMBER
0410000220

**BOARD FOR ARCHITECTS, PROFESSIONAL ENGINEERS, LAND SURVEYORS, CERTIFIED INTERIOR DESIGNERS
AND LANDSCAPE ARCHITECTS**
PROFESSIONAL CORPORATION BRANCH OFFICE REGISTRATION

PROFESSIONS: ENG



RINKER DESIGN ASSOCIATES PC
4301 DOMINION BOULEVARD, SUITE 100
GLEN ALLEN, VA 23060



Jimmy W. DeBoer
Jimmy W. DeBoer, Director

Status can be verified at <http://www.dpor.virginia.gov>

COMMONWEALTH of VIRGINIA
Department of Professional and Occupational Regulation
9960 Mayland Drive, Suite 400, Richmond, VA 23233
Telephone: (804) 367-8500

EXPIRES ON
12-31-2017

NUMBER
0405000502

**BOARD FOR ARCHITECTS, PROFESSIONAL ENGINEERS, LAND SURVEYORS, CERTIFIED INTERIOR DESIGNERS
AND LANDSCAPE ARCHITECTS**
PROFESSIONAL CORPORATION REGISTRATION

PROFESSIONS: ENG, LS



RINKER DESIGN ASSOCIATES PC
9385 DISCOVERY BOULEVARD, STE 200
MANASSAS, VA 20109



Jimmy W. DeBoer
Jimmy W. DeBoer, Director

Status can be verified at <http://www.dpor.virginia.gov>

COMMONWEALTH of VIRGINIA

Department of Professional and Occupational Regulation
9960 Mayland Drive, Suite 400, Richmond, VA 23233
Telephone: (804) 367-8500

EXPIRES ON
04-30-2018

NUMBER
4008001739

REAL ESTATE APPRAISER BOARD
APPRAISAL BUSINESS REGISTRATION



RINKER DESIGN ASSOCIATES PC
927 MAPLE GROVE DR STE 105
FREDERICKSBURG, VA 22407



Jimmy W. DeBoer
Jimmy W. DeBoer, Director

Status can be verified at <http://www.dpor.virginia.gov>

COMMONWEALTH of VIRGINIA

Department of Professional and Occupational Regulation
9960 Mayland Drive, Suite 400, Richmond, VA 23233
Telephone: (804) 367-8500

EXPIRES ON
04-30-2018

NUMBER
4008001801

REAL ESTATE APPRAISER BOARD
APPRAISAL BUSINESS REGISTRATION



RINKER DESIGN ASSOCIATES P C
4301 DOMINION BOULEVARD
SUITE 100
GLEN ALLEN, VA 23060



Jimmy W. DeBoer
Jimmy W. DeBoer, Director

Status can be verified at <http://www.dpor.virginia.gov>

DEPARTMENT OF PROFESSIONAL AND OCCUPATIONAL REGULATION

COMMONWEALTH OF VIRGINIA

9960 Mayland Dr., Suite 400, Richmond, VA 23233
Telephone: (804) 367-8500

EXPIRES ON
02-28-2017

NUMBER
4008001684

REAL ESTATE APPRAISER BOARD
APPRAISAL BUSINESS REGISTRATION

RINKER DESIGN ASSOCIATES PC
9385 DISCOVERY BOULEVARD
SUITE 200
MANASSAS, VA 20109



Jimmy W. DeBoer
Jimmy W. DeBoer, Director

ALTERATION OF THIS DOCUMENT, USE AFTER EXPIRATION, OR USE BY PERSONS OR FIRMS OTHER THAN THOSE NAMED MAY RESULT IN CRIMINAL PROSECUTION UNDER THE CODE OF VIRGINIA.

ATTACHMENT 4.2.5

State Project No. 0095-111-278

SCC and DPOR Information

Offerors shall complete the table and include the required state registration and licensure information. By completing this table, Offerors certify that their team complies with the requirements set forth in Section 4.2.5 and that all businesses listed are active and in good standing.

SCC & DPOR INFORMATION FOR BUSINESSES (RFP Sections 4.2.5.1 and 4.2.5.2)							
Business Name	SCC Information (4.2.5.1)			DPOR Information (4.2.5.2)			
	SCC Number	SCC Type of Corporation	SCC Status	DPOR Registered Address	DPOR Registration Type	DPOR Registration Number	DPOR Expiration Date
Branscome, Inc. LEAD CONTRACTOR	05506134	Corporation	Active	432 McLaws Cir Williamsburg, VA 23185	Highway/Heavy (H/H)	2705061347	02/28/2017
Rinker Design Associates, P.C. (RDA) LEAD DESIGNER AND QAM FIRM	0227062-7	S-Corporation	Active	927 Maple Grove Dr Suite 105 Fredericksburg, VA 22407 (Branch)	Engineering (ENG), Land Surveying (LS)	0410000156	02/28/2018
					Real Estate Appraisal Business	4008001739	04/30/2018
				4301 Dominion Blvd Suite 100 Glen Allen, VA 23060 (Branch)	Engineering (ENG)	0410000220	02/28/2018
					Real Estate Appraisal Business	4008001801	04/30/2018
				9385 Discovery Blvd Suite 200 Manassas, VA 20109 (Main)	Engineering (ENG), Land Surveying (LS)	0405000502	12/31/2017
					Real Estate Appraisal Business	4008001684	02/28/2017

ATTACHMENT 4.2.6(a)

LEAD CONTRACTOR - WORK HISTORY FORM

(LIMIT 1 PAGE PER PROJECT)

a. Project Name & Location	b. Name of the prime design consulting firm responsible for the overall project design.	c. Contact information of the Client or Owner and their Project Manager who can verify Firm's responsibilities.	d. Contract Completion Date (Original)	e. Contract Completion Date (Actual or Estimated)	f. Contract Value (in thousands)		g. Dollar Value of Work Performed by the Firm identified as the Lead Contractor for this procurement (in thousands)
					Original Contract Value	Final or Estimated Contract Value	
Name: VDOT Order 5B3 Princess Anne Road Location: Virginia Beach, VA	Name: Virginia Department of Transportation (VDOT)	Name of Client/ Owner: VDOT Phone: 757-253-5141 Project Manager: Mr. Mitch Layton Phone: 757-494-5481 Email: mitch.layton@vdot.virginia.gov	05/2014	05/2014	\$28,142	\$29,662	\$24,448

h. Narrative describing the Work Performed by the Firm identified as the Lead Contractor for this procurement. If the Offeror chooses to submit work completed by an affiliated or subsidiary company of the Lead Contractor, identify the full legal name of the affiliate or subsidiary and the role they will have on this Project, so the relevancy of that work can be considered accordingly. The Work History Form shall include only one singular project. Projects with multiple phases, segments, elements, and/or contracts shall not be considered a single project. If a project listed includes multiple phases, segments, elements, and/or contracts, the SOQ may be rendered non-responsive. In any case, only the first phase, segment, element, and/or contract listed will be evaluated.

Branscome, Inc. was the prime contractor for the Princess Anne Road / Nimmo Parkway Widening Project, which began in Fall 2010. The primary roadway connects the Virginia Beach Municipal Complex with the Dam Neck Road / Princess Anne Road intersection. The two existing lanes of Princess Anne Road were widened to four lanes with additional turn lanes and two major intersections, including new and upgraded signalization. The project also included the construction of one mile of four-lane primary road, an extension of Nimmo Parkway. Extensive utility relocations and upgrades included the installation of more than 15,000 feet of storm sewer pipe, 6,000 feet of sanitary sewer pipe, and 18,000 feet of water lines. Other aspects of the project included a multi-use path on both sides of the road, 26,000 linear feet of curb and gutter, 800 feet of 30-foot sound wall, four storm water management ponds, and aesthetic improvements such as brick paver crosswalks, decorative walls, and landscape improvements. The road design consisted of asphalt pavement over cement treated aggregate placed over stabilized soils. Asphalt paving included more than 40,000 tons of base mix, 12,000 tons of intermediate mix, and 14,000 tons of surface mix. The project also included an accepted value engineering (V.E.) proposal, which saved VDOT \$1.5 million and six months of project duration. The original project included over \$1.8 million in signalization and electrical work. The V.E. cost savings were later reinvested into the project as a change order to provide the City of Virginia Beach with lighting for the multi-purpose paths throughout the project. The total electrical and signalization cost for the project exceeded \$3.3 million.

The project was managed using a formal partnering agreement formed between the key stakeholders on the job. Branscome, VDOT, the City of Virginia Beach, and others collaborated before work began to agree on a cooperative approach that would ensure everyone's goals were met when the job was completed. These goals included ensuring the safety of all personnel on the job as well as the traveling public, delivering a high quality final product, protecting the environment during construction, completing the project on time, and having a project that stayed within budget.



ATTACHMENT 4.2.6(a)

LEAD CONTRACTOR - WORK HISTORY FORM

(LIMIT 1 PAGE PER PROJECT)

a. Project Name & Location	b. Name of the prime design consulting firm responsible for the overall project design.	c. Contact information of the Client or Owner and their Project Manager who can verify Firm's responsibilities.	d. Contract Completion Date (Original)	e. Contract Completion Date (Actual or Estimated)	f. Contract Value (in thousands)		g. Dollar Value of Work Performed by the Firm identified as the Lead Contractor for this procurement. (in thousands)
					Original Contract Value	Final or Estimated Contract Value	
Name: Commander Shepard Boulevard Extension Phase 1 Location: Hampton, VA	Name: Virginia Department of Transportation (VDOT)	Name of Client/ Owner: City of Hampton Phone: 757-727-6101 Project Manager: Michael Hodges Phone: 757-727-6101 Email: mhoadge@hampton.gov	05/2010	05/2011	\$12,695	\$14,034	\$8,419

h. Narrative describing the Work Performed by the Firm identified as the Lead Contractor for this procurement. If the Offeror chooses to submit work completed by an affiliated or subsidiary company of the Lead Contractor, identify the full legal name of the affiliate or subsidiary and the role they will have on this Project, so the relevancy of that work can be considered accordingly. The Work History Form shall include only one singular project. Projects with multiple phases, segments, elements, and/or contracts shall not be considered a single project. If a project listed includes multiple phases, segments, elements, and/or contracts, the SOQ may be rendered non-responsive. In any case, only the first phase, segment, element, and/or contract listed will be evaluated.

This project created a new east-west corridor in Hampton, which would serve Langley Air Force Base and new development anticipated in the area. The project extended Commander Shepard Boulevard from Magruder Boulevard to the intersection of North Campus Parkway. The project involved a new interchange at Commander Shepard Boulevard and Magruder Boulevard, which included a new overpass bridge, four ramps, and two loops. The project's scopes of work included asphalt paving, demolition, grading, excavation, structures, guardrail, striping, electrical, and signalization. Since this project was located along a heavily used thoroughfare (Magruder Boulevard), the safe maintenance of traffic was a top priority as the existing Commander Sheppard Boulevard served as one of the major access routes to the NASA Research facility and Langley Air Force Base. The project completion date was extended by the City of Hampton due to extensive change orders requested by the City for additional roadway and ground improvements. Branscome's work was completed in accordance with the City's revised construction schedule. This primary roadway included traffic signals and electrical work which accounted for \$1.4 million of the project scope, approximately 10% of the value of the contract.



ATTACHMENT 4.2.6(a)

LEAD CONTRACTOR - WORK HISTORY FORM

(LIMIT 1 PAGE PER PROJECT)

a. Project Name & Location	b. Name of the prime design consulting firm responsible for the overall project design.	c. Contact information of the Client or Owner and their Project Manager who can verify Firm's responsibilities.	d. Contract Completion Date (Original)	e. Contract Completion Date (Actual or Estimated)	f. Contract Value (in thousands)		g. Dollar Value of Work Performed by the Firm identified as the Lead Contractor for this procurement. (in thousands)
					Original Contract Value	Final or Estimated Contract Value	
Name: I-64 Pavement Rehabilitation Design-Build Location: Norfolk, VA	Name: Dewberry	Name of Client/ Owner: VDOT Phone: 757-494-5472 Project Manager: Robert A. Morgan Phone: 757-376-2606 Email: robert.morgan@vdot.virginia.gov	11/2014	1/2015	\$14,450	\$15,448	\$10,968

h. Narrative describing the Work Performed by the Firm identified as the Lead Contractor for this procurement. If the Offeror chooses to submit work completed by an affiliated or subsidiary company of the Lead Contractor, identify the full legal name of the affiliate or subsidiary and the role they will have on this Project, so the relevancy of that work can be considered accordingly. The Work History Form shall include only one singular project. Projects with multiple phases, segments, elements, and/or contracts shall not be considered a single project. If a project listed includes multiple phases, segments, elements, and/or contracts, the SOQ may be rendered non-responsive. In any case, only the first phase, segment, element, and/or contract listed will be evaluated.

Branscome was the Lead Contractor for this Design-Build project in Norfolk. The primary intent of the project was to repair existing pavements and then construct a pavement overlay on one of VDOT's busiest interstates – 20 lane miles of I-64 between the Hampton Roads Bridge Tunnel (HRBT) and Little Creek Bridge in Norfolk. The overall scope of work included design, QA/QC, 3,400 square yards of concrete patching, 27,000 tons of SMA paving, 7,000 tons of Thin Hot Mix Asphalt Concrete Overlay (THMACO), 2,000 linear feet of median barrier wall refacing, and 40,000 linear feet of guardrail and asphalt curb modifications. The major challenges of this project, which had to be overcome to ensure successful completion, were the accelerated schedule, the need for several construction activities to be performed concurrently, the urban nature of the work area, and substantial public involvement.

The design phase of the project began in January 2014, and the project was scheduled for completion by the end of November 2014. The challenge of completing the project on time was exasperated by three major factors:

- First, the design had to be completed, submitted to VDOT, and approved before construction could begin. Branscome addressed this problem by breaking the project into smaller segments and fully developing the design for each to allow construction to begin as early as March for the first section. This was all done while keeping a constant eye on the schedule to ensure that key items and areas of work were completed on time and making sure the critical path was not negatively impacted.
- Second, there were two other major paving projects on the Interstate being constructed simultaneously project as well as regular maintenance to both I-64 and the HRBT. This led to conflicts between the projects over priority for lane closures and availability of specific sections of the highway where work could be performed, since there was some inevitable overlapping between the various projects. Branscome addressed this by working with VDOT and the other contractors to create a proactive dialogue where each party would inform the others of overall schedules and key milestone dates to prevent conflicts from resulting in delays.
- Third, there were strict limits on when construction in active travel lanes could be performed, since that section of I-64 is a heavily traveled, crucial transportation asset. Branscome worked to develop an efficient operation which optimized the available time to perform the work, consistently having four to six crews onsite each night, and quickly reopened all travel lanes before the morning rush hour.

As previously mentioned, this project was in one of the busiest highway corridors in Hampton Roads and adjacent to several traffic chokepoints including I-564 and the HRBT. This made maintenance of traffic an essential element of the project both with regards to safety and minimizing impact to the travelling public, minimizing impact to the traveling public. Branscome worked diligently starting in the design phase to develop plans which would allow progress to continue on the project while still providing safe and easy access through the work zone. By addressing this issue in the design phase, Branscome was able to prevent more significant problems from arising later in the project. The urban nature of the work also made material delivery a potential issue, since construction materials, especially stone, asphalt, and concrete, had to reach the job on time to ensure productions were met. Branscome addressed this by having approved materials available at several different facilities in Hampton Roads.

Public Involvement was a key element to the success of the project. This was a marquee project for VDOT and the Hampton Roads public, since the condition of the interstates had received significant negative feedback prior to the start of these jobs. If the public did not see almost immediate progress, if construction snarled traffic for weeks on end, or if clear communication did not give motorists advanced warning regarding what work was taking place, then there would be a terrible backlash directed all parties involved with the project. Branscome addressed this potential pitfall by contracting a public relation and communications firm, Polizos & Company, to regularly update the public and other key stakeholders on the progress of the project. This outreach included maintenance of website specifically focused on the project, social media updates, press releases, use of signs and message boards in the construction area, and educational information distributed to key locations. All pavement repairs and overlay were completed and all sections of I-64 within the project limits were fully open to the public before the contract completion date. This was accomplished despite significant overruns to the concrete patching. The project is substantially complete, and Branscome is currently waiting on final approval from VDOT.



ATTACHMENT 4.2.6(b)

LEAD DESIGNER - WORK HISTORY FORM

(LIMIT 1 PAGE PER PROJECT)

a. Project Name & Location	b. Name of the prime/ general contractor responsible for overall construction of the project.	c. Contact information of the Client and their Project Manager who can verify Firm's responsibilities.	d. Construction Contract Start Date	e. Construction Contract Completion Date (Actual or Estimated)	f. Contract Value (in thousands)		g. Design Fee for the Work Performed by the Firm identified as the Lead Designer for this procurement.(in thousands)
					Construction Contract Value (Original)	Construction Contract Value (Actual or Estimated)	
Name: I-581/Elm Avenue Interchange Improvement Location: Roanoke, VA	Name: Allan Myers, Inc. (Formerly American Infrastructure – VA, Inc.)	Name of Client: VDOT Phone: 540-378-5038 Project Manager: Mr. Robert Phlegar Phone: 540-378-5038 Email: r.phlegar@vdot.virginia.gov	06/2015	06/2015	\$20,400	\$20,400	\$1,507

h. Narrative describing the Work Performed by the Firm identified as the Lead Designer for this procurement. Include the office location(s) where the design work was performed and whether the firm was the prime designer or a subconsultant. The Work History Form shall include only one singular project. Projects with multiple phases, segments, elements, and/or contracts shall not be considered a single project. If a project listed includes multiple phases, segments, elements, and/or contracts, the SOQ may be rendered non-responsive. In any case, only the first phase, segment, element, and/or contract listed will be evaluated.

RDA performed the design services on this project as the Prime Designer out of their Glen Allen Office. The project consists of changes to both Elm Avenue and I-581. Changes to Elm Avenue included a four-lane divided highway, urban minor arterial typical section (GS-6) with curb and gutter, and raised median (1,200 linear feet). Changes to I-581 included a six-lane divided highway, freeway/other principal arterial (GS-5), and median barrier. The project scope included complete roadway and bridge design along with construction for 0.3 miles of widening and reconstruction on Elm Avenue to include the replacement of two bridges (one over I-581 and the other over the Norfolk Southern Railroad). The project also included reconstruction of all four ramps to provide additional capacity and better traffic flow. Finally, the project includes guardrail replacement along I-581 to current standards along with the replacement of a 60-inch pipe crossing with an 84-inch pipe (originally designed using micro-tunneling technology).

As the Lead Designer for the I-581/Elm Avenue Design-Build project, RDA is responsible for the following critical project elements:

Roadway Design (includes typical section development, horizontal and vertical geometry, TMP/MOT Plans, signage (including major overhead signing), pavement marking, and signalization plans)

- Drainage Design (roadway drainage, erosion/sediment control, and major drainage (box culverts and 84-inch culvert design) requiring detailed analysis)
- Environmental Support (avoidance strategies and permit sketches/drawings preparation for impacted areas)
- Right of Way Acquisition (responsible for right of way and easement acquisition from 5 affected parcels)
- Utility Relocation Coordination (responsible for holding UFI meeting, developing easement requirements, evaluating UT-9 forms to determine cost responsibility, reviewing utility plan and estimates, and monitoring the relocation of utilities including the relocation of Norfolk Southern's signal line)
- Subconsultant Management (activities performed by subconsultants reporting to RDA include geotechnical, bridge design, surveying, and underground utility designation and location)



ATTACHMENT 4.2.6(b)

LEAD DESIGNER - WORK HISTORY FORM

(LIMIT 1 PAGE PER PROJECT)

a. Project Name & Location	b. Name of the prime/ general contractor responsible for overall construction of the project.	c. Contact information of the Client and their Project Manager who can verify Firm's responsibilities.	d. Construction Contract Start Date	e. Construction Contract Completion Date (Actual or Estimated)	f. Contract Value (in thousands)		g. Design Fee for the Work Performed by the Firm identified as the Lead Designer for this procurement.(in thousands)
					Construction Contract Value (Original)	Construction Contract Value (Actual or Estimated)	
Name: Route 15 Improvements Design-Build/PPTA Location: Prince William County, VA	Name: Branch Highways, Inc.	Name of Client.: Prince William County Phone: 703-792-6825 Project Manager: Mr. Ricardo Canizales Phone: 703-792-6825 Email: rcanizales@pwcgov.org	12/2009	12/2009	\$56,430	\$56,430	\$4,119

h. Narrative describing the Work Performed by the Firm identified as the Lead Designer for this procurement. Include the office location(s) where the design work was performed and whether the firm was the prime designer or a subconsultant. The Work History Form shall include only one singular project. Projects with multiple phases, segments, elements, and/or contracts shall not be considered a single project. If a project listed includes multiple phases, segments, elements, and/or contracts, the SOQ may be rendered non-responsive. In any case, only the first phase, segment, element, and/or contract listed will be evaluated.

RDA was the Lead Designer providing engineering design services, right of way acquisition services, environmental permitting, and construction engineering and inspection services for the Route 15 PPTA project in the Town of Haymarket (Prince William County), Virginia. The project consisted of complete roadway and bridge construction for 2.2 miles of U.S. Route 15, 0.3 mile of Waterfall Road, 0.7 mile of Old Carolina Road and 0.3 mile of Heathcote Boulevard. The project also included construction of an additional 1.2 miles of Route 15 widening designed by others. Project limits were from the I-66/Route 15 interchange in the south to the Route 15/Route 234 intersection to the north; this included construction of bridge structures over Little Bull Run Creek and Catharpin Creek and a major box culvert at the Tributary to Catharpin Creek. RDA served as the Prime Engineering Consultant to Branch Highways, Inc., the Lead Contractor/Project Constructor responsible for development and construction. The project was performed as a Design-Build venture under the Virginia PPTA Act of 1995.

As the Lead Designer for the Route 15 PPTA, RDA was responsible for the following critical project elements:

- Roadway Design (included typical section development, horizontal and vertical geometry, signage and pavement marking plans, signalization plans, and maintenance of traffic plans)
- Drainage Design (included drainage analysis, roadway drainage design, erosion and sediment control plans, and major drainage design (box culverts) requiring floodplain analyses and H&HA)
- Environmental Permitting (provided complete permitting services for all 5 phases of the project)
- Right of Way Acquisition (responsible for right of way and easement acquisition for over 50 impacted parcels)
- Utility Relocation Coordination (responsible for holding the UFI meeting, developing easement requirements, evaluating UT-9 forms to determine cost responsibility, reviewing utility plans and estimates, and monitoring the relocation of affected utilities)
- Public Involvement (included meeting with special interest groups including homeowners' associations and County Supervisors)
- Subconsultant Management (activities performed by subconsultants reporting to RDA included geotechnical investigations, bridge design, traffic analysis, and underground utility designation and location)



ATTACHMENT 4.2.6(b)

LEAD DESIGNER - WORK HISTORY FORM

(LIMIT 1 PAGE PER PROJECT)

a. Project Name & Location	b. Name of the prime/ general contractor responsible for overall construction of the project.	c. Contact information of the Client and their Project Manager who can verify Firm's responsibilities.	d. Construction Contract Start Date	e. Construction Contract Completion Date (Actual or Estimated)	f. Contract Value (in thousands)		g. Design Fee for the Work Performed by the Firm identified as the Lead Designer for this procurement. (in thousands)
					Construction Contract Value (Original)	Construction Contract Value (Actual or Estimated)	
Name: Prince William Parkway Widening Location: Prince William County, VA	Name: Branch Highways, Inc.	Name of Client: Prince William County Phone: 703-792-6825 Project Manager: Mr. Ricardo Canizales Phone: 703-792-6825 Email: rcanizales@pwcgov.org	12/2010	12/2012	\$12,540	\$12,540	\$1,877

h. Narrative describing the Work Performed by the Firm identified as the Lead Designer for this procurement. Include the office location(s) where the design work was performed and whether the firm was the prime designer or a subconsultant. The Work History Form shall include only one singular project. Projects with multiple phases, segments, elements, and/or contracts shall not be considered a single project. If a project listed includes multiple phases, segments, elements, and/or contracts, the SOQ may be rendered non-responsive. In any case, only the first phase, segment, element, and/or contract listed will be evaluated.

RDA provided comprehensive engineering services to the Prince William County Department of Transportation for the widening of Prince William Parkway (Route 294) from Hoadly Road to Old Bridge Road (approximate length of 6,500 linear feet). This project widened Prince William Parkway, an urban minor arterial and a vital component to the County's transportation network, to its ultimate six-lane configuration in accordance with the County's Comprehensive Plan. The project included federal (ARRA) funding and was designed on an accelerated schedule necessary to meet federal funding obligation requirements (Notice to Proceed to Advertisement is less than one year). Key project elements/requirements include: VDOT Plan Approval, Design Waiver Preparation and processing, NEPA compliance documentation (categorical exclusion), survey (boundary and topo), traffic analysis, five signal modifications, private developer coordination, right of way acquisition assistance, utility relocation coordination, cost estimating, and bid assistance.





COMMONWEALTH OF VIRGINIA

DEPARTMENT OF TRANSPORTATION

PLAN AND PROFILE OF PROPOSED STATE HIGHWAY

DESIGN-BUILD CONCEPTUAL PLANS

CITY OF FREDERICKSBURG
INTERSTATE 95
FROM: 0.115 MILES SOUTH OF INT. ROUTE 3
TO: 1.220 MILES NORTH OF INT. ROUTE 3

0095-III-278, PE-101, RW-201, & C-501

FHWA 534 DATA 31103

STATE	FEDERAL AID PROJECT	ROUTE	STATE PROJECT	SHEET NO.
VA.	OC-095-2() (SEE TABULATION BELOW FOR SECTION NUMBERS)	95	(NF0)0095-III-278 (SEE TABULATION BELOW FOR SECTION NUMBERS)	1

THIS PROJECT WAS DEVELOPED UTILIZING THE DEPARTMENT'S ENGINEERING DESIGN PACKAGE (GEOPAK).
GEOPAK Computer Identification No. 107715

FUNCTIONAL CLASSIFICATION AND TRAFFIC DATA

FUNCTIONAL CLASSIFICATION	I-95 RAMPS		
	SB I-95 OFF RAMP TO WB RTE. 3 (Ramp B)	NB I-95 ON RAMP FROM EB RTE. 3 (Ramp A, Loop D)	SB I-95 ON LOOP FROM WB RTE. 3 (Loop B)
MIN. DESIGN SPEED	25 MPH / 50 MPH	30 MPH / 50 MPH	25 MPH
ADT (2014)	18,900	8,847 (1) 19,176 (2)	3,900
ADT (2038)	30,100	40,100	5,800
DHV	2,400	3,200	460
D (%) (design hour)	N/A	N/A	N/A
T (%) (design hour)	5%	5%	5%
V (MPH)	X	X	X
TC STD.	TC-5.11R	TC-5.11R	TC-5.11R
GEOMETRIC STD.	GS-R	GS-R	GS-R
MIN. VERTICAL CLEARANCE	16'-6"	16'-6"	16'-6"

X See Plan Sheets for horizontal curve data speeds.
Design Vehicle: AASHTO 2011 WB-67

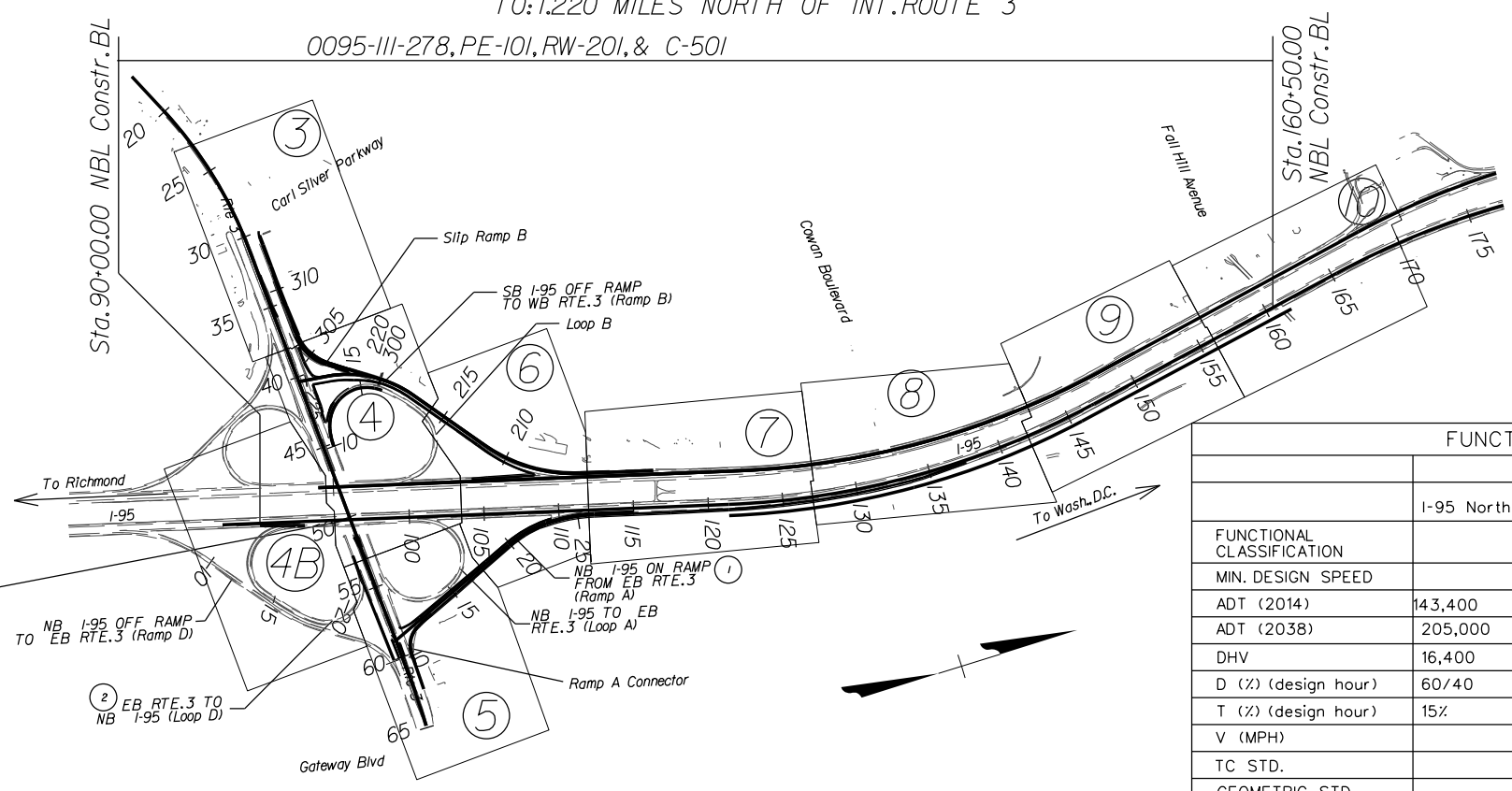

DESCRIPTION REFERENCE:
STA. 96+05.42 I-95 NBL CONSTR. BASELINE
STA. 50+17.08 ROUTE 3 CONSTR. BASELINE

COUNTY LINE
CITY, TOWN OR VILLAGE
RIGHT OF WAY LINE
FENCE LINE
UNFENCED PROPERTY LINE
FENCED PROPERTY LINE
WATER LINE
SANITARY SEWER LINE
GAS LINE
ELECTRIC UNDERGROUND CABLE
TRAVELED WAY
GUARD RAIL
RETAINING WALL
RAILROADS
BASE OR SURVEY LINE

LEVEE OR EMBANKMENT
BRIDGES
CULVERTS
DROP INLET
POWER POLES
TELEPHONE OR TELEGRAPH POLES
TELEPHONE OR TELEGRAPH LINES
HEDGE
TREES
HEAVY WOODS
GROUND ELEVATION
GRADE ELEVATION

FUNCTIONAL CLASSIFICATION	I-95		ROUTE 3	
	I-95 North of Route 3	I-95 South of Route 3	From: I-95 Bridge To: Carl Silver Parkway	From: I-95 Bridge To: Gateway Blvd
MIN. DESIGN SPEED	70 MPH		45 MPH	
ADT (2014)	143,400	115,062	90,093	60,590
ADT (2038)	205,000	165,900	107,000	75,800
DHV	16,400	13,600	8,600	6,100
D (%) (design hour)	60/40	60/40	60/40	55/45
T (%) (design hour)	15%	15%	4%	5%
V (MPH)		X		X
TC STD.		TC 5.11R		TC 5.11ULS
GEOMETRIC STD.		GS-5		GS-5
MIN. VERTICAL CLEARANCE		16'-6"		16'-6"

X See Plan Sheets for horizontal curve data speeds.
Design Vehicle: AASHTO 2011 WB-67

STATE PROJECT NO.	SECTION	FEDERAL AID PROJECT NO.	TYPE CODE	UPC NO.	EQUALITIES		LENGTH INCLUDING BRIDGE(S)		LENGTH EXCLUDING BRIDGE(S)		TYPE PROJECT	DESCRIPTION
					FEET		FEET	MILES	FEET	MILES		
0095-III-278	PE-101	OC-095-2(535)	PENG	107715			7050.00	1.335	7050.00	1.335	PRELIM. ENGR.	FROM: 0.115 MILES SOUTH OF INT. ROUTE 3 TO: 1.220 MILES NORTH OF INT. ROUTE 3
	RW-201	OC-095-2(535)	ROWA	107715			7050.00	1.335	7050.00	1.335	RIGHT OF WAY	
	C-501	OC-095-2(535)	1000	107715			7050.00	1.335	7050.00	1.335	CONSTRUCTION	

Population 24,286 (2010 Census, Fredericksburg)

Stafford County Population 128,961 (2010 Census) X

Project Lengths are based on Northbound I-95 Mainline Construction Baseline.



Copyright 2016, Commonwealth of Virginia

PROJECT	SHEET NO.
0095-III-278	1

PROJECT MANAGER _____
SURVEYED BY, DATE _____
DESIGN BY _____
SUBSURFACE UTILITY BY, DATE _____

REVISED	STATE	ROUTE	STATE PROJECT	SHEET NO.
	VA.	95	0095-III-278, P-101, RW-201, C-501	2A

DESIGN FEATURES RELATING TO CONSTRUCTION OR TO REGULATION AND CONTROL OF TRAFFIC MAY BE SUBJECT TO CHANGE AS DEEMED NECESSARY BY THE DEPARTMENT

TYPICAL SECTIONS

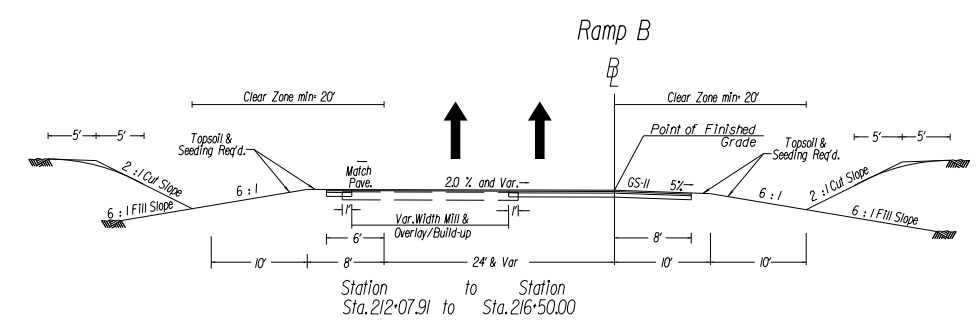
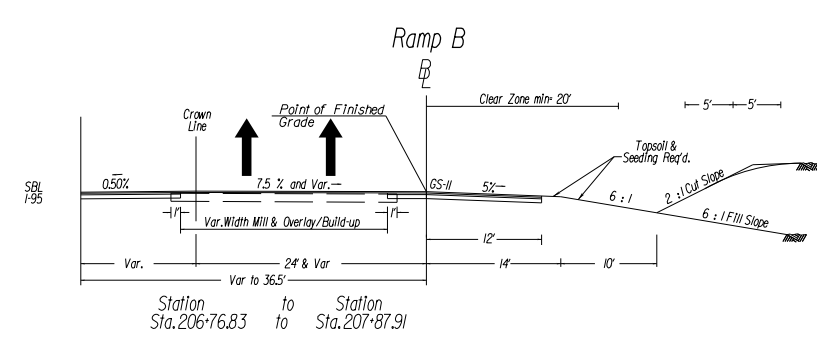
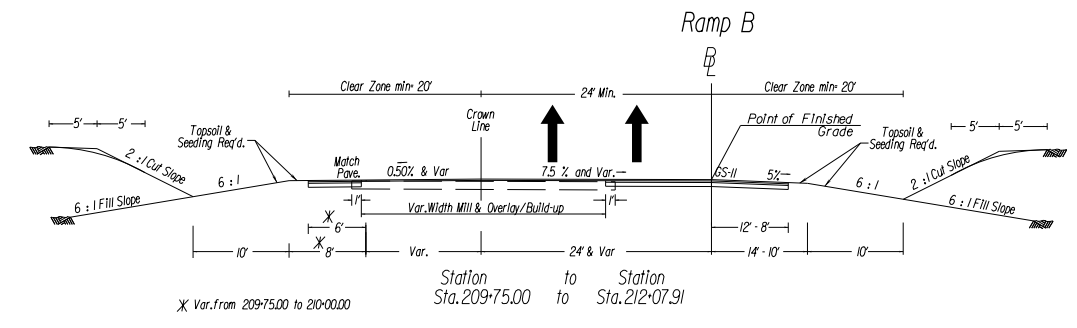
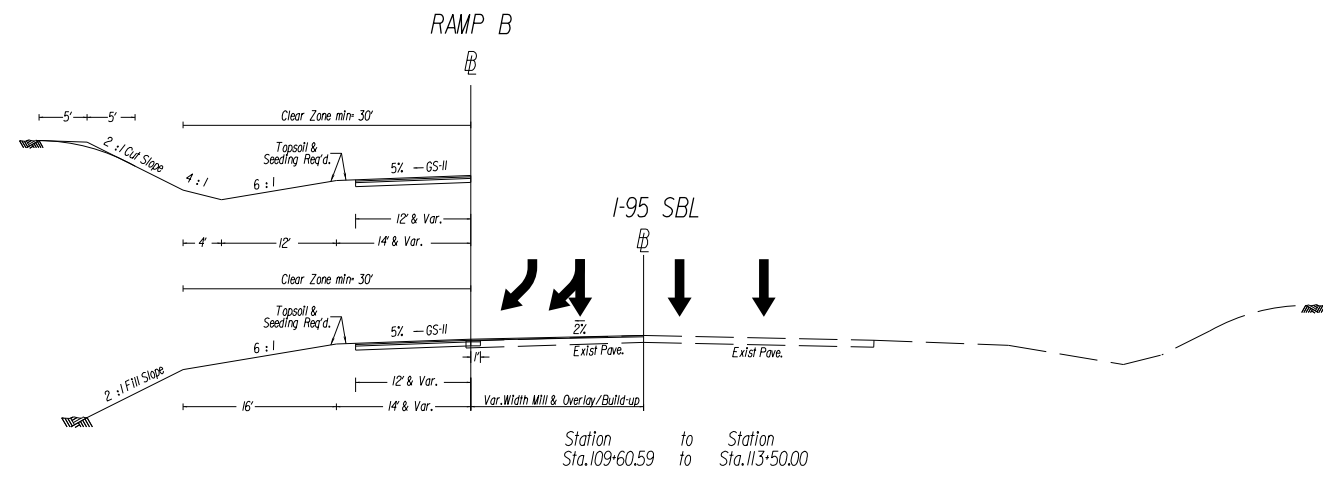
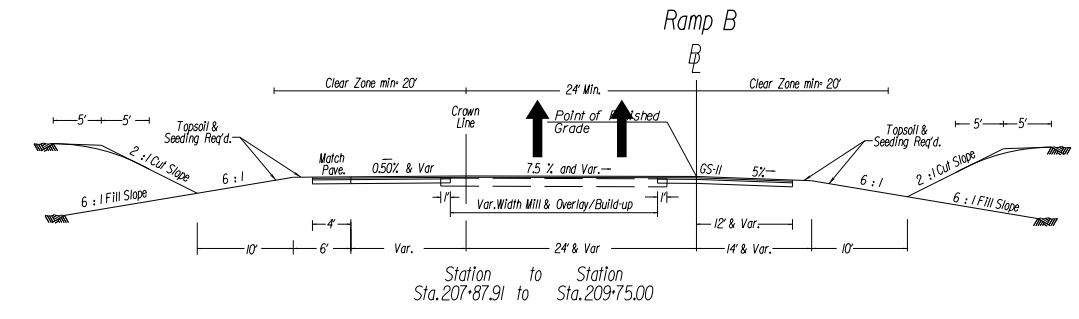
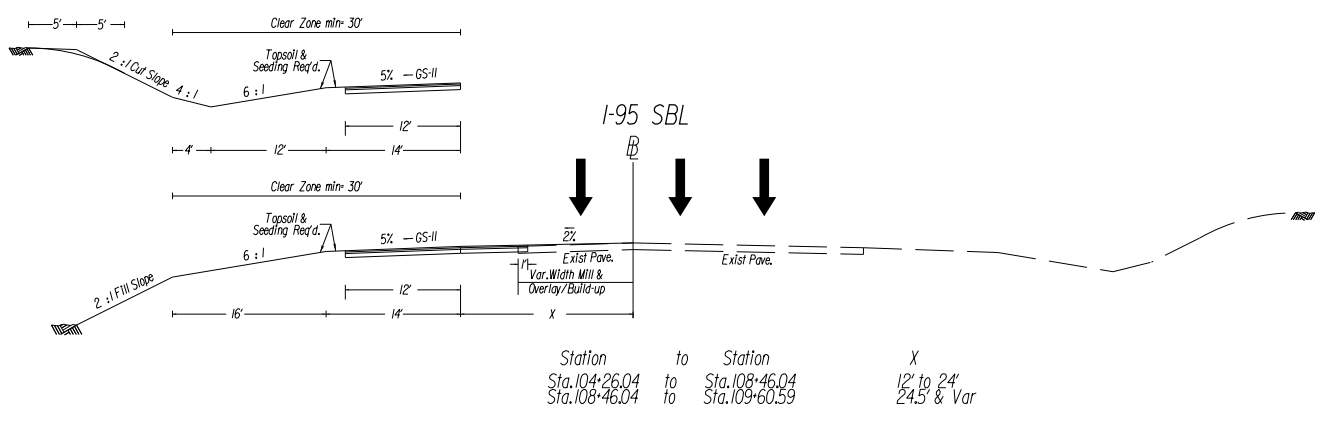

VDOT COMMONWEALTH OF VIRGINIA
 DEPARTMENT OF TRANSPORTATION

Interstate 95 / Route 3 Interchange

BRANSCOME INCORPORATED

rda

PROJECT 0095-III-278
 SHEET NO. 2A

TYPICAL SECTIONS

REVISED	STATE	ROUTE	STATE PROJECT	SHEET NO.
	VA.	95	0095-III-278, P-101, RW-201, C-501	2B

DESIGN FEATURES RELATING TO CONSTRUCTION OR TO REGULATION AND CONTROL OF TRAFFIC MAY BE SUBJECT TO CHANGE AS DEEMED NECESSARY BY THE DEPARTMENT

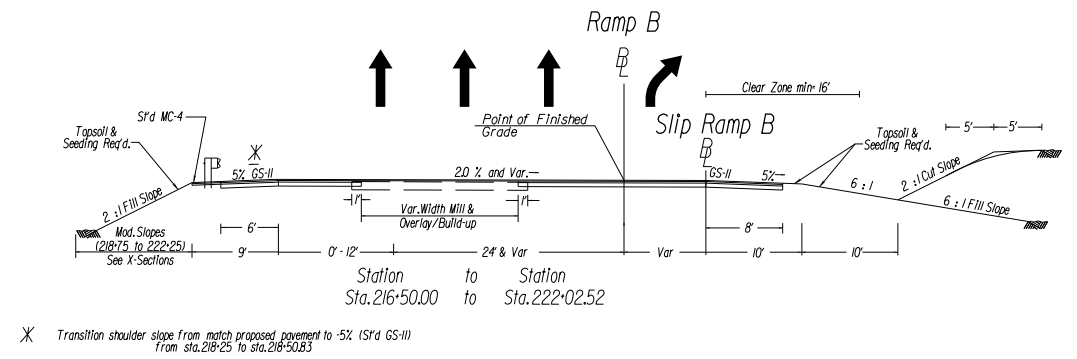

X Transition shoulder slope from match proposed pavement to 5% (Srd GS-II) from sta. 218+25 to sta. 218+50.83

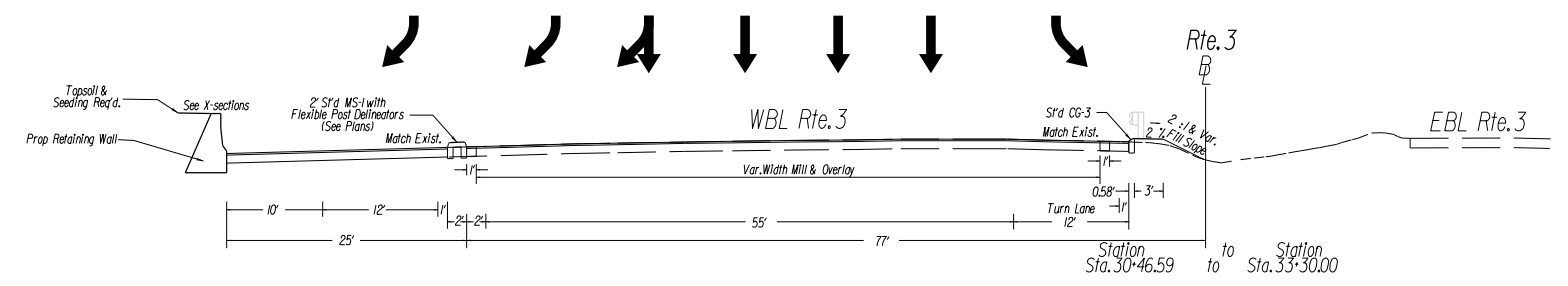
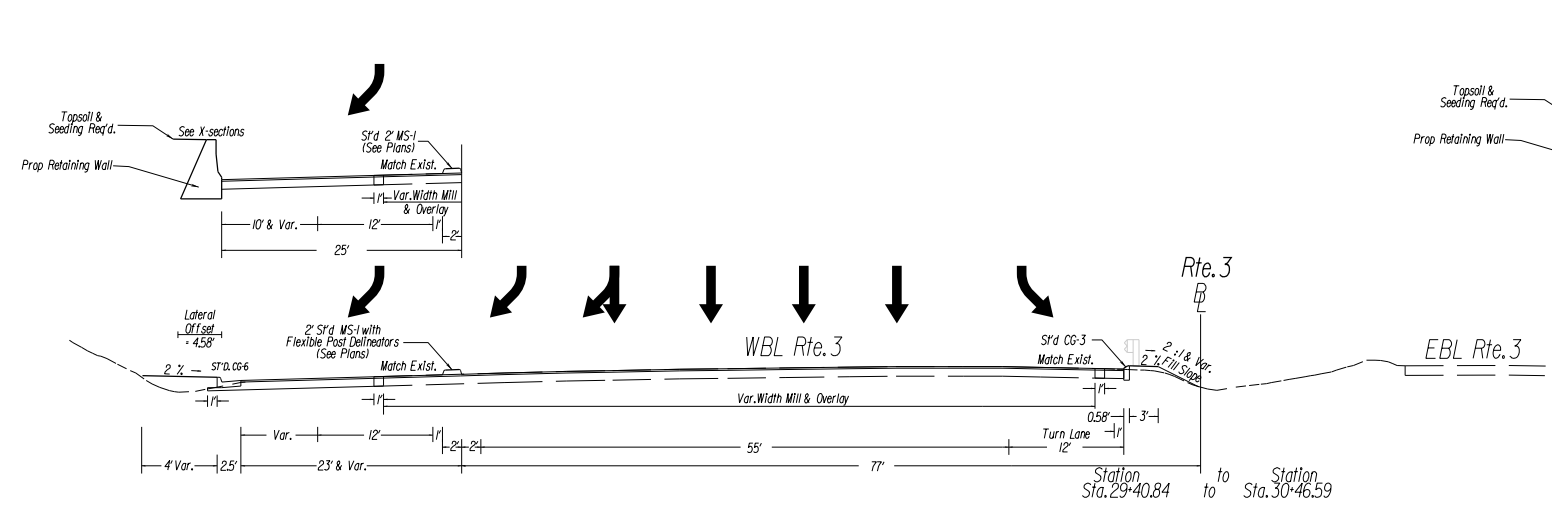
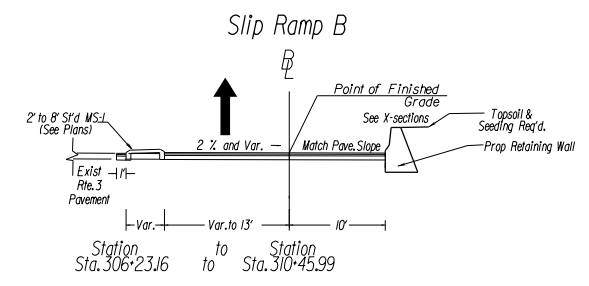
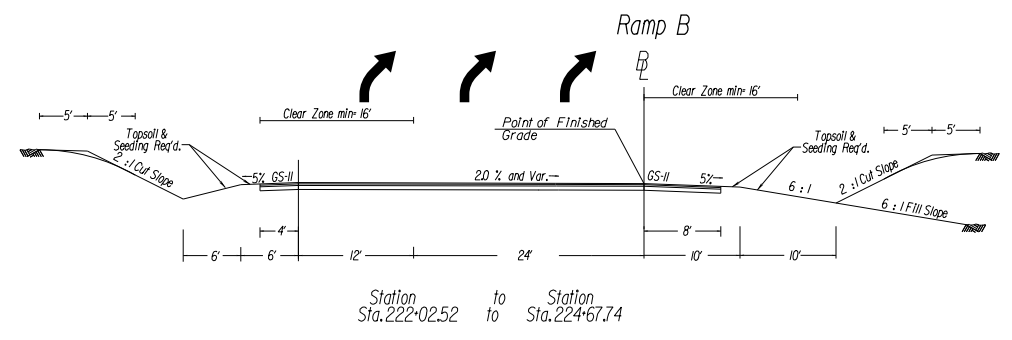
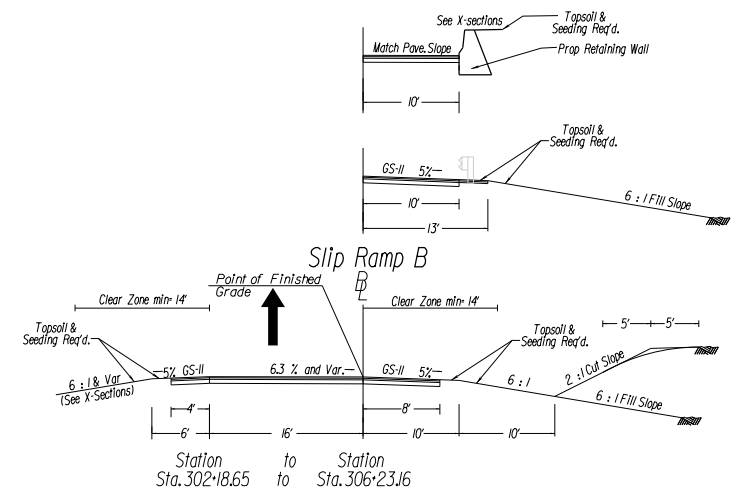

VDOT COMMONWEALTH OF VIRGINIA
DEPARTMENT OF TRANSPORTATION

Interstate 95 / Route 3 Interchange

BRANSCOME INCORPORATED

rda

PROJECT 0095-III-278 SHEET NO. 2B

TYPICAL SECTIONS

REVISED	STATE	ROUTE	STATE PROJECT	SHEET NO.
	VA.	95	0095-III-278, P-101, RW-201, C-501	2C

DESIGN FEATURES RELATING TO CONSTRUCTION OR TO REGULATION AND CONTROL OF TRAFFIC MAY BE SUBJECT TO CHANGE AS DEEMED NECESSARY BY THE DEPARTMENT

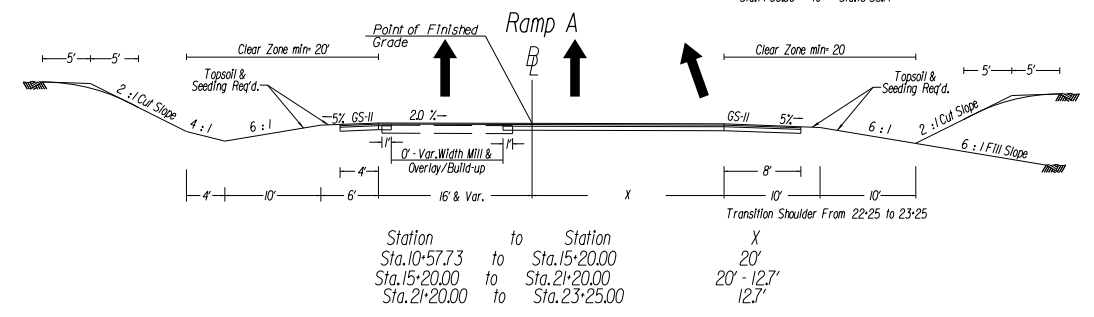
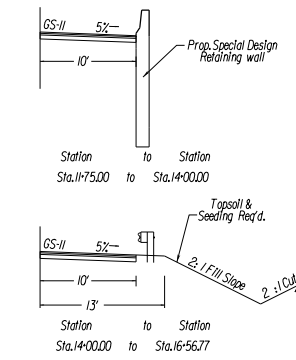
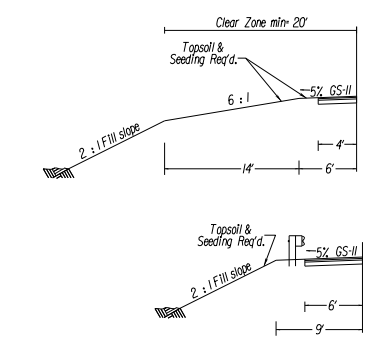
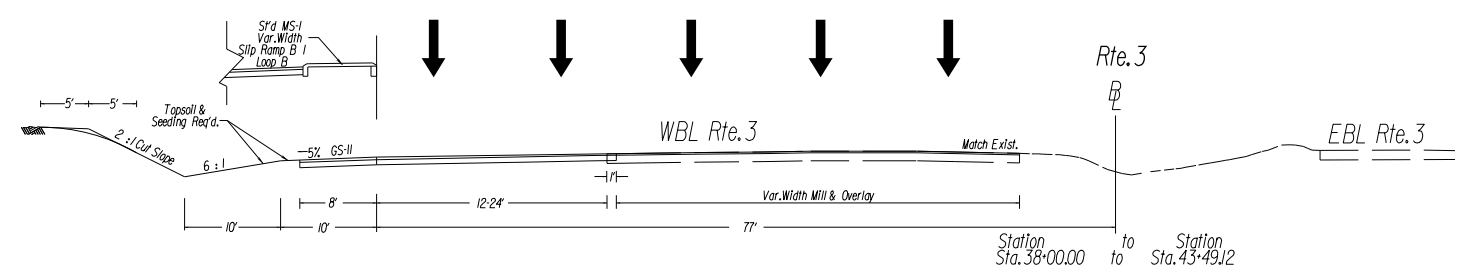
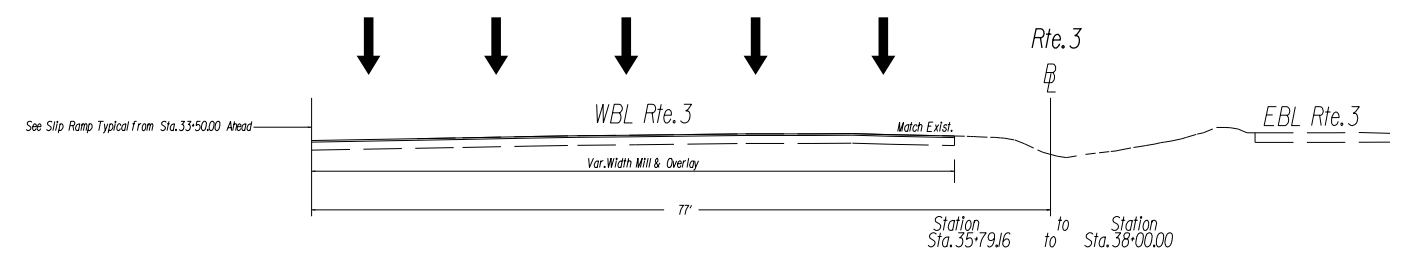
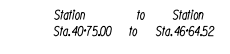
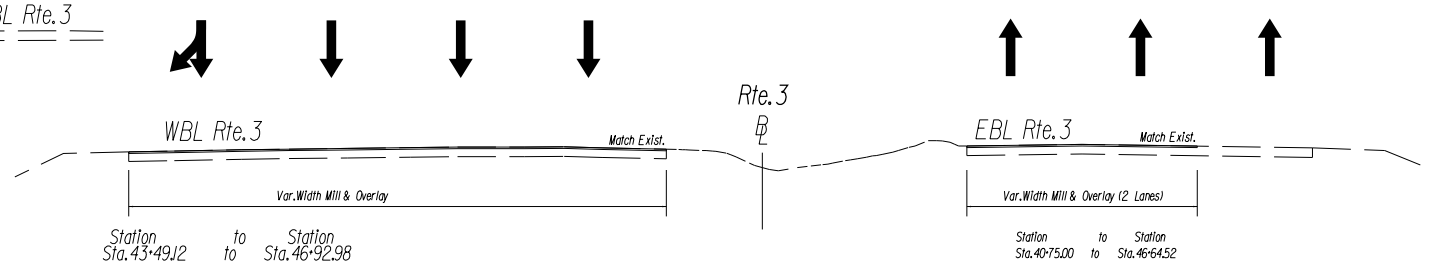
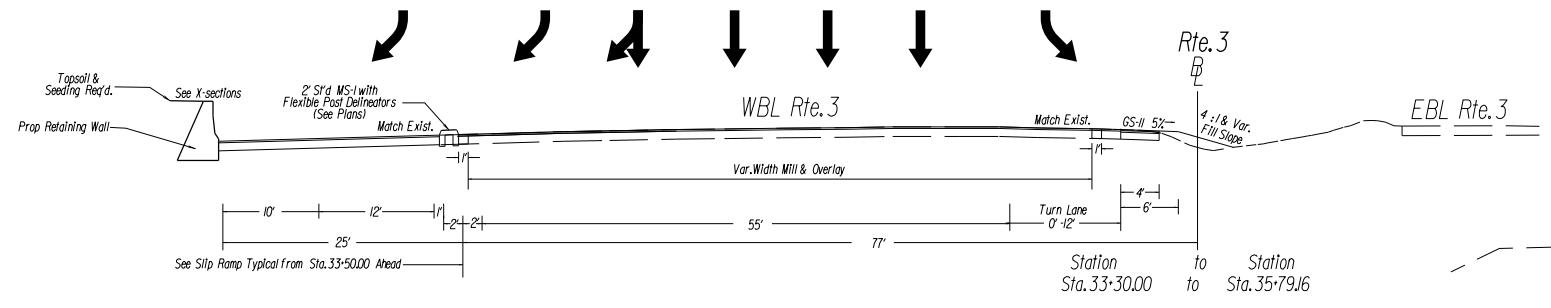

VDOT COMMONWEALTH OF VIRGINIA
DEPARTMENT OF TRANSPORTATION

Interstate 95 / Route 3 Interchange

BRANSCOME INCORPORATED

rda

PROJECT 0095-III-278 SHEET NO. 2C

TYPICAL SECTIONS

REVISED	STATE	ROUTE	STATE PROJECT	SHEET NO.
	VA.	95	0095-III-278, P-101, RW-201, C-501	2D

DESIGN FEATURES RELATING TO CONSTRUCTION OR TO REGULATION AND CONTROL OF TRAFFIC MAY BE SUBJECT TO CHANGE AS DEEMED NECESSARY BY THE DEPARTMENT

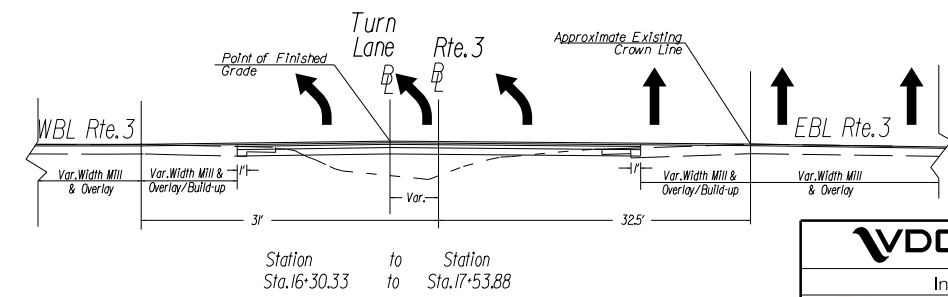
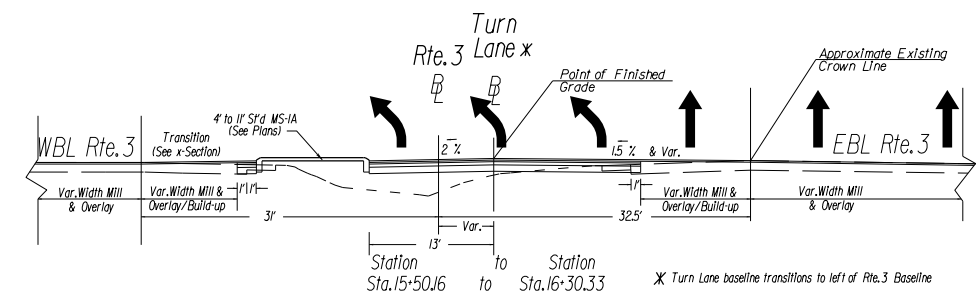
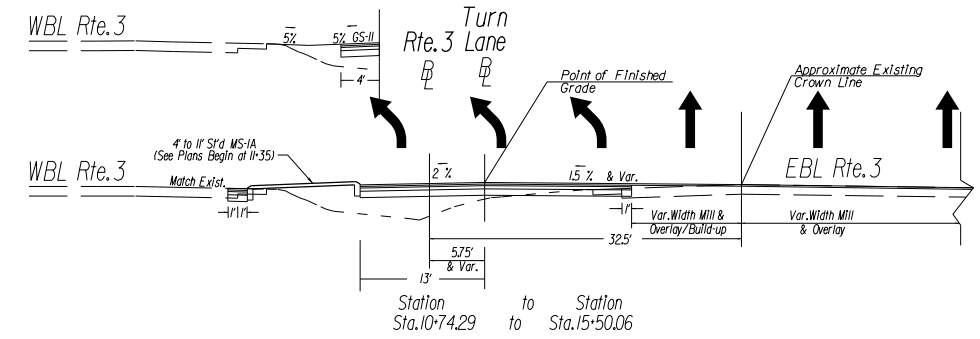
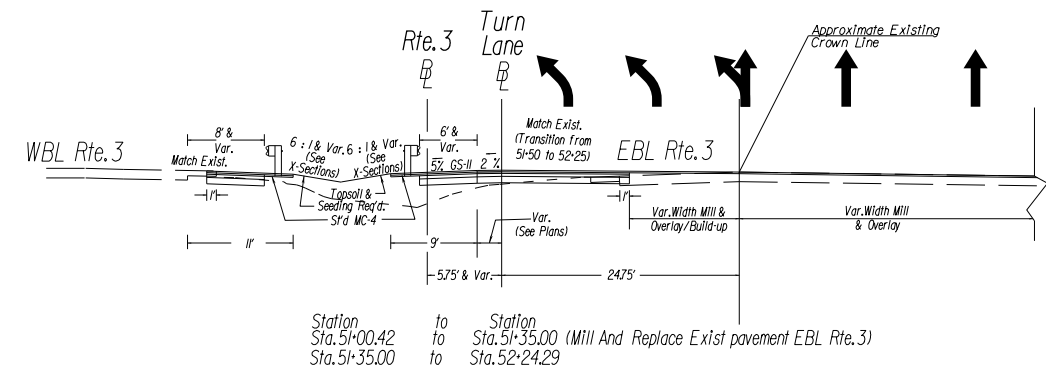
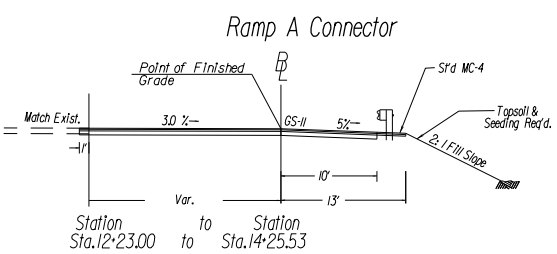
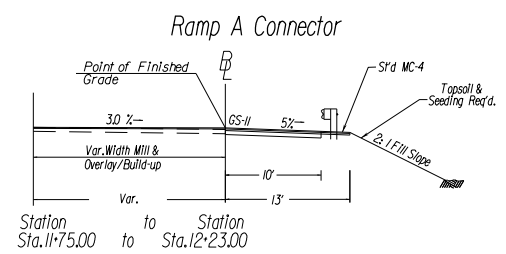
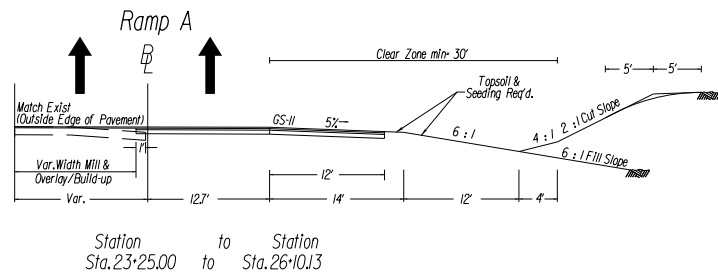

VDOT COMMONWEALTH OF VIRGINIA
DEPARTMENT OF TRANSPORTATION

Interstate 95 / Route 3 Interchange

BRANSCOME INCORPORATED

rda

PROJECT 0095-III-278 SHEET NO. 2D

TYPICAL SECTIONS

REVISED	STATE	ROUTE	STATE PROJECT	SHEET NO.
	VA.	95	0095-III-278, P-101, RW-201, C-501	2E

DESIGN FEATURES RELATING TO CONSTRUCTION OR TO REGULATION AND CONTROL OF TRAFFIC MAY BE SUBJECT TO CHANGE AS DEEMED NECESSARY BY THE DEPARTMENT

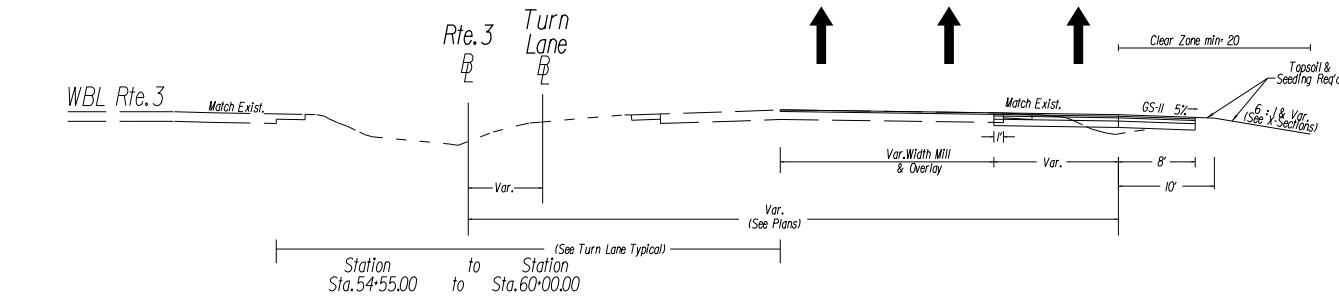
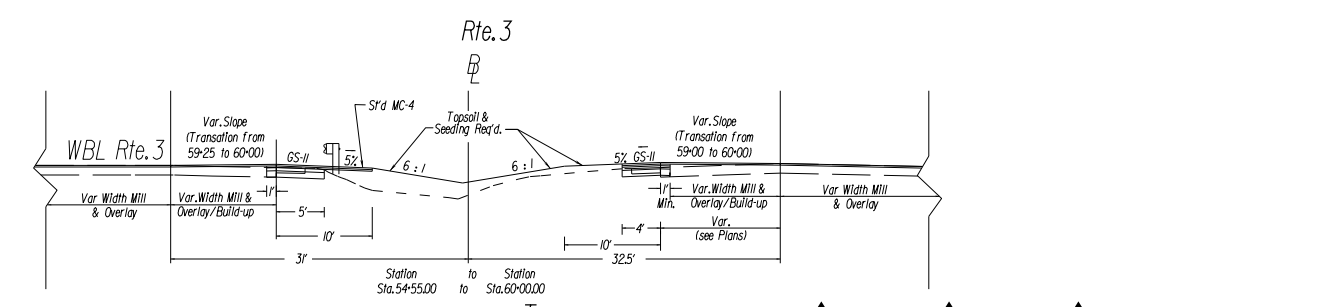
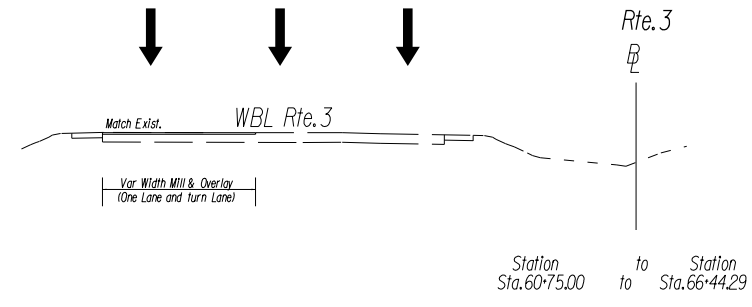
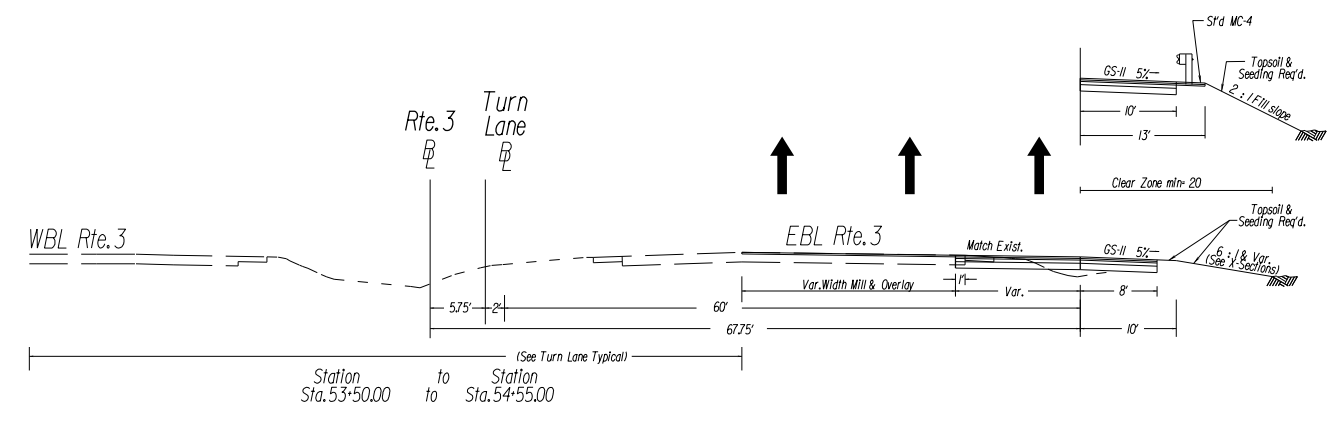
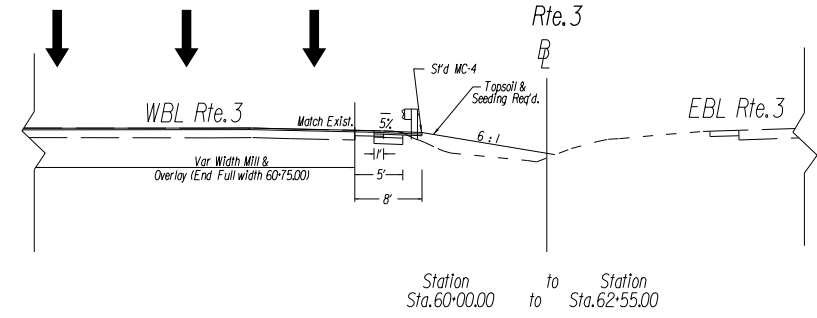
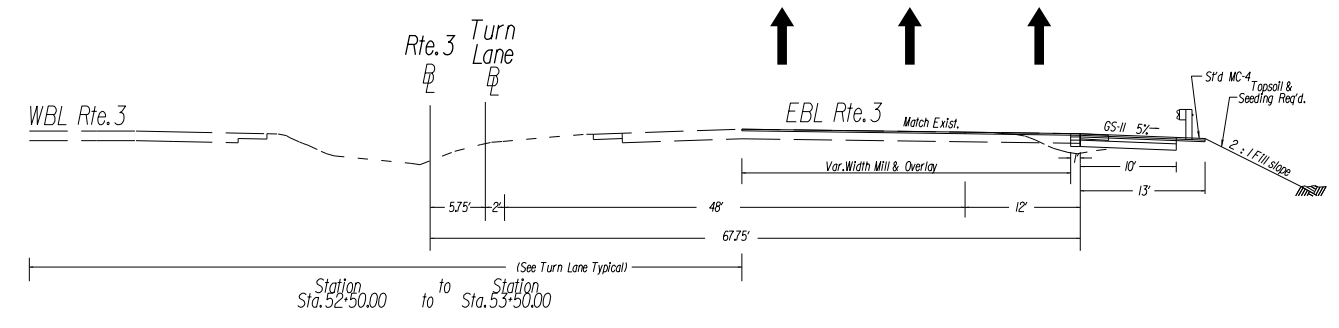

VDOT COMMONWEALTH OF VIRGINIA
 DEPARTMENT OF TRANSPORTATION

Interstate 95 / Route 3 Interchange

BRANSCOME INCORPORATED

rda

PROJECT 0095-III-278 SHEET NO. 2E

TYPICAL SECTIONS

REVISED	STATE	ROUTE	PROJECT	SHEET NO.
	VA.	95	0095-III-278, P-101, RW-201, C-501	2F

DESIGN FEATURES RELATING TO CONSTRUCTION OR TO REGULATION AND CONTROL OF TRAFFIC MAY BE SUBJECT TO CHANGE AS DEEMED NECESSARY BY THE DEPARTMENT

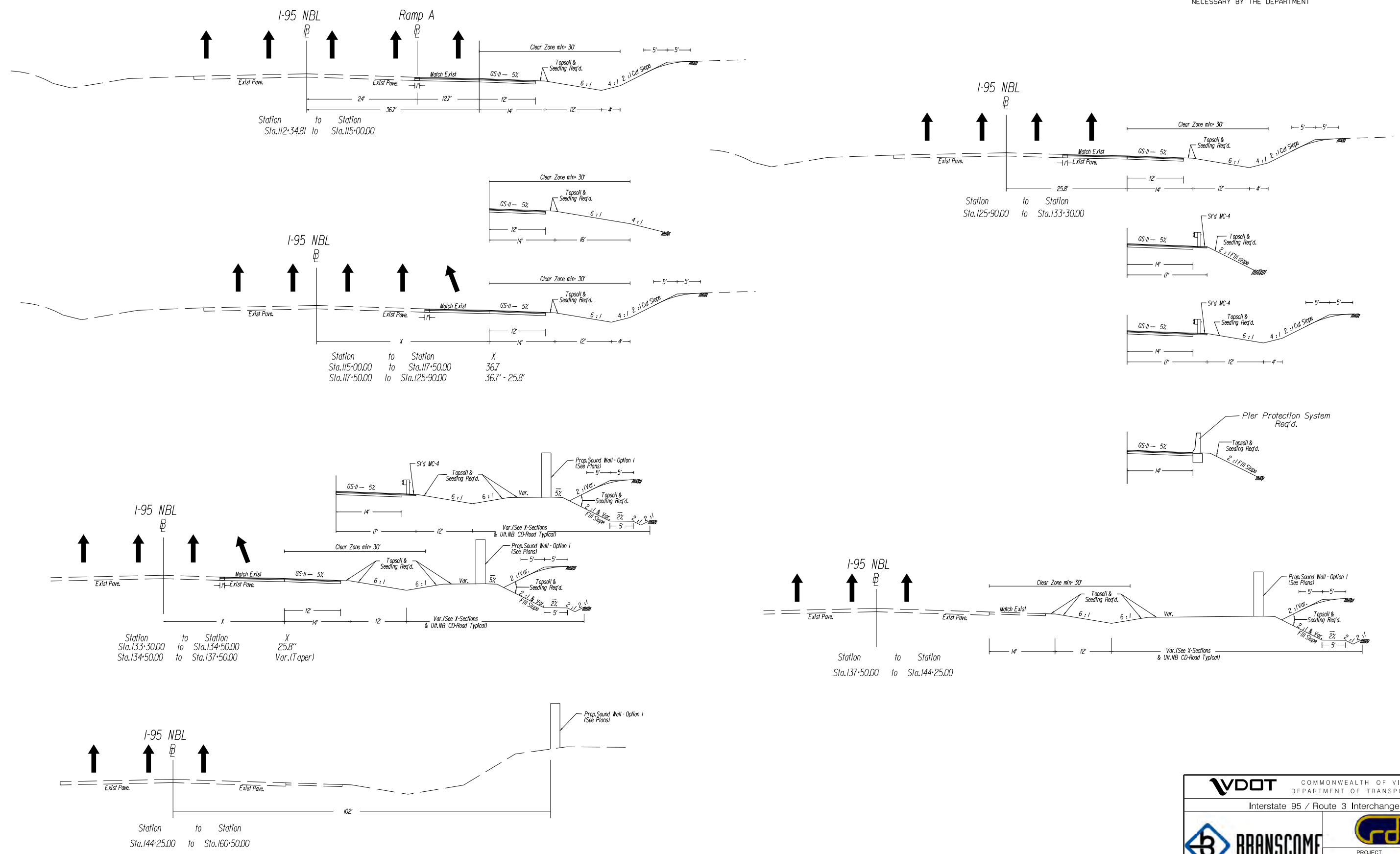

VDOT COMMONWEALTH OF VIRGINIA
DEPARTMENT OF TRANSPORTATION

Interstate 95 / Route 3 Interchange

BRANSCOME INCORPORATED

rda

PROJECT: 0095-III-278
SHEET NO.: 2F

TYPICAL SECTIONS

REVISED	STATE	ROUTE	STATE PROJECT	SHEET NO.
	VA.	95	0095-III-278, P-101, RW-201, C-501	2G

DESIGN FEATURES RELATING TO CONSTRUCTION OR TO REGULATION AND CONTROL OF TRAFFIC MAY BE SUBJECT TO CHANGE AS DEEMED NECESSARY BY THE DEPARTMENT

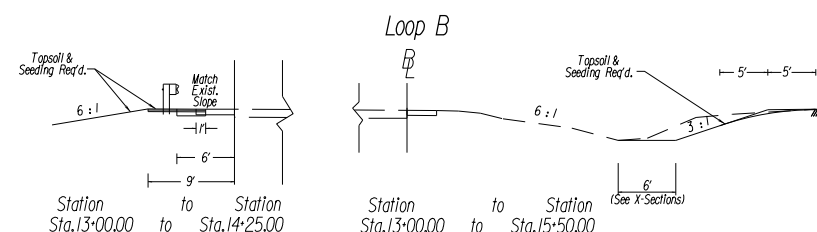
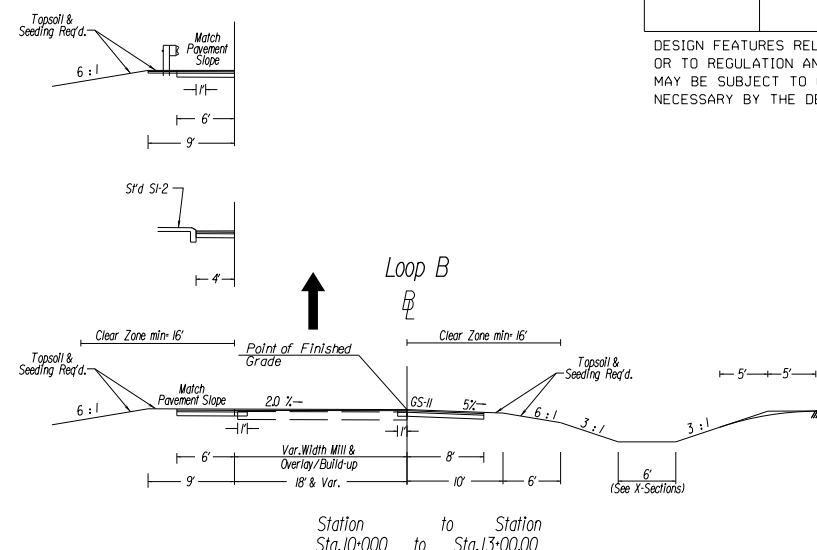
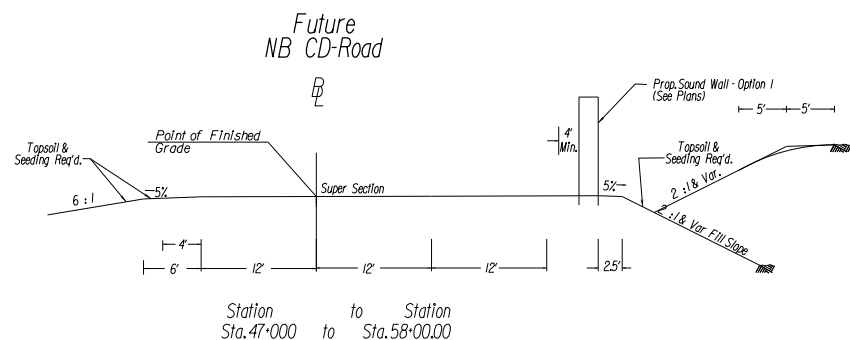

Minimum Pavement Sections

I-95 Widening (North and Southbound Lanes)

Surface - 220 lbs/SY Asphalt Concrete Type, SM 12.5 E
 Intermediate - 220 lbs/SY Asphalt Concrete, Type, IM-19.0D
 Base - 8 Inches Asphalt Concrete Type, BM 25.0 A
 Subbase - 8 Inches Aggregate Base Material, Type 1, 2IB to be connected to VDOT Standard UD-4 edgdrain

I-95 Shoulder Design (North and Southbound directions)

Surface - 220 lbs/SY Asphalt Concrete Type, SM 12.5 A
 Intermediate - 220 lbs/SY Asphalt Concrete, Type, IM-19.0D
 Base - 8 Inches Asphalt Concrete Type, BM 25.0A
 Subbase - 8 Inches Aggregate Base Material, Type 1, 2IB

All Ramps (A, B and Loop B), Slip Ramp B, Route 3 east and Route 3 west

Surface - 220 lbs/SY Asphalt Concrete Type, SM 12.5 E
 Intermediate - 220 lbs/SY Asphalt Concrete, Type, IM-19.0D
 Base - 6 Inches Asphalt Concrete Type, BM 25.0A
 Subbase - 8 Inches Aggregate Base Material, Type 1, 2IB to be extended and daylighted in locations where curb and gutter is available, install VDOT Standard UD-4 edge drains and tie to drop inlets for positive drainage.

Ramps (A and B), Slip Ramp, Route 3, Loop B and Route 3 west Shoulder Design

Surface - 220 lbs/SY Asphalt Concrete Type, SM 12.5 A
 Intermediate - 220 lbs/SY Asphalt Concrete, Type, IM-19.0D
 Base - 6 Inches Asphalt Concrete Type, BM 25.0A
 Subbase - 8 Inches Aggregate Base Material, Type 1, 2IB to be extended and daylighted

All Other Areas

Surface - 220 lbs/SY Asphalt Concrete Type, SM 12.5 D
 Intermediate - 220 lbs/SY Asphalt Concrete, Type, IM-19.0A
 Subbase - 8 Inches Aggregate Base Material, Type 1, 2IB

Mill and Overlay

For salvage/build-up areas, the existing pavement shall be milled two (2) inches and replaced with 220 lbs/SY, Asphalt Concrete Type, SM 12.5E

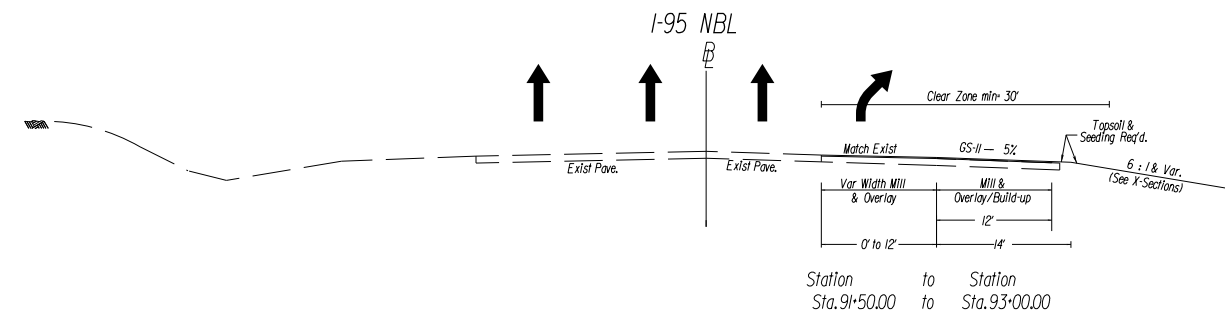
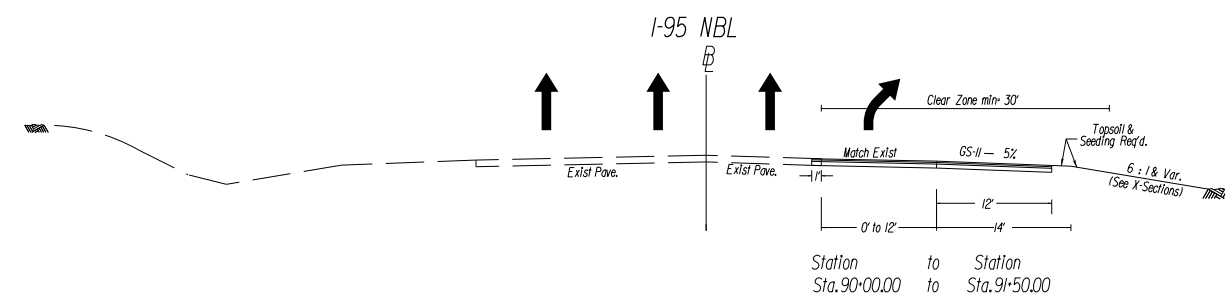

VDOT COMMONWEALTH OF VIRGINIA
 DEPARTMENT OF TRANSPORTATION

Interstate 95 / Route 3 Interchange

BRANSCOME INCORPORATED

rda

PROJECT 0095-III-278 SHEET NO. 2G

REVISED	STATE	ROUTE	STATE PROJECT	SHEET NO.
	VA.	95	0095-III-278, P-101, RW-201, C-501	3

SEE TYPICAL SECTIONS FOR
LANE, SHOULDER, AND MEDIAN
WIDTHS.

DESIGN FEATURES RELATING TO CONSTRUCTION
OR TO REGULATION AND CONTROL OF TRAFFIC
MAY BE SUBJECT TO CHANGE AS DEEMED
NECESSARY BY THE DEPARTMENT

Utility Owners:

Water and Sewer: City of Fredericksburg
Department of Public Works
Bassam Amin
City of Fredericksburg
P.O. Box 7447
Fredericksburg, VA 22404
(540)-372-1023 ext. 251
bamin@fredericksburgva.gov

Power: Dominion Virginia Power
Susan Smith
7500 West Broad Street
Richmond, VA 23294
Mobile: (804)-839-9960
susan.s.smith@dom.com

Telecomm: Comcast (CMC)
Mark Sheriff
4391 Dale Blvd
Woodbridge, VA 22193
(804)-385-6664
Mark_Sheriff@cable.comcast.com

Verizon (VZN)
William (Bill) Lacy
Verizon Project Designer / Highway Relocations
9401 Peabody Street Manassas, VA 20110
office (703)-369-9571 fax (703)-330-7323
cell (540)-520-1905
william.lacy@verizon.com

Gas: Columbia Gas
NISource Damage Prevention Screening
1600 Dublin Road
Marble Cliff, Ohio 43215
Cell: (614)-315-6524
Office: (614)-481-1456
Fax: (614)-481-1264
CDCDamagePreventionCenter@nisource.com

Anderson Propane
Brian Stanley
(540)-295-5831

SummitIG (SIG)
Steve Ragland
22375 Broadrick Dr.
Suite 165
Dulles, VA 20166
(804)-317-4483
sragland@summitig.com

Cox Communications (COX)
James Cummings
1310 Belman Road
Fredericksburg, VA 22401
(517)-237-8596
James.Cummings@cox.com

PEG Bandwidth (PEG)
Michael Llamas
8532 Skip Jack Pl
Pasadena, MD 21122
(443)-827-1786
mlamas@pegbandwidth.com

Sidera Networks (SID)
Rick Stransky
(801)-669-4175

FREDERICKSBURG 35, LLC
Inst# 02001343
PB 12 PG 45
0399 AC
GPN# 7769-52-9998

ANDERSON PROPANE
Inst# 02001343
PB 12 PG 45
0399 AC
GPN# 7769-52-9998

THE CENTRAL PARK PROPERTY OWNERS ASSOCIATION, INC.
Inst# 04000745
PB 9 PG 54
2332 AC
GPN# 7769-62-4926

CARL D. SILVER ESTATE
Inst# 02001343
PB 12 PG 45
0399 AC
GPN# 7769-52-9998

CENTRAL PARK 122X, LLC
Inst# 02001343
PB 12 PG 45
0399 AC
GPN# 7769-52-9998

CENTRAL PARK 120X, LLC
Inst# 02001343
PB 12 PG 45
0399 AC
GPN# 7769-52-9998

FREDERICKSBURG 35, LLC
Inst# 02001343
PB 12 PG 45
0399 AC
GPN# 7769-52-9998

CENTRAL PARK 120X, LLC
Inst# 02001343
PB 12 PG 45
0399 AC
GPN# 7769-52-9998

CENTRAL PARK 120X, LLC
Inst# 02001343
PB 12 PG 45
0399 AC
GPN# 7769-52-9998

FREDERICKSBURG 35, LLC
Inst# 02001343
PB 12 PG 45
0399 AC
GPN# 7769-52-9998

CENTRAL PARK 120X, LLC
Inst# 02001343
PB 12 PG 45
0399 AC
GPN# 7769-52-9998

FREDERICKSBURG 35, LLC
Inst# 02001343
PB 12 PG 45
0399 AC
GPN# 7769-52-9998

CENTRAL PARK 120X, LLC
Inst# 02001343
PB 12 PG 45
0399 AC
GPN# 7769-52-9998

FREDERICKSBURG 35, LLC
Inst# 02001343
PB 12 PG 45
0399 AC
GPN# 7769-52-9998

CENTRAL PARK 120X, LLC
Inst# 02001343
PB 12 PG 45
0399 AC
GPN# 7769-52-9998

FREDERICKSBURG 35, LLC
Inst# 02001343
PB 12 PG 45
0399 AC
GPN# 7769-52-9998

CENTRAL PARK 120X, LLC
Inst# 02001343
PB 12 PG 45
0399 AC
GPN# 7769-52-9998

FREDERICKSBURG 35, LLC
Inst# 02001343
PB 12 PG 45
0399 AC
GPN# 7769-52-9998

CENTRAL PARK 120X, LLC
Inst# 02001343
PB 12 PG 45
0399 AC
GPN# 7769-52-9998

FREDERICKSBURG 35, LLC
Inst# 02001343
PB 12 PG 45
0399 AC
GPN# 7769-52-9998

CENTRAL PARK 120X, LLC
Inst# 02001343
PB 12 PG 45
0399 AC
GPN# 7769-52-9998

FREDERICKSBURG 35, LLC
Inst# 02001343
PB 12 PG 45
0399 AC
GPN# 7769-52-9998

CENTRAL PARK 120X, LLC
Inst# 02001343
PB 12 PG 45
0399 AC
GPN# 7769-52-9998

FREDERICKSBURG 35, LLC
Inst# 02001343
PB 12 PG 45
0399 AC
GPN# 7769-52-9998

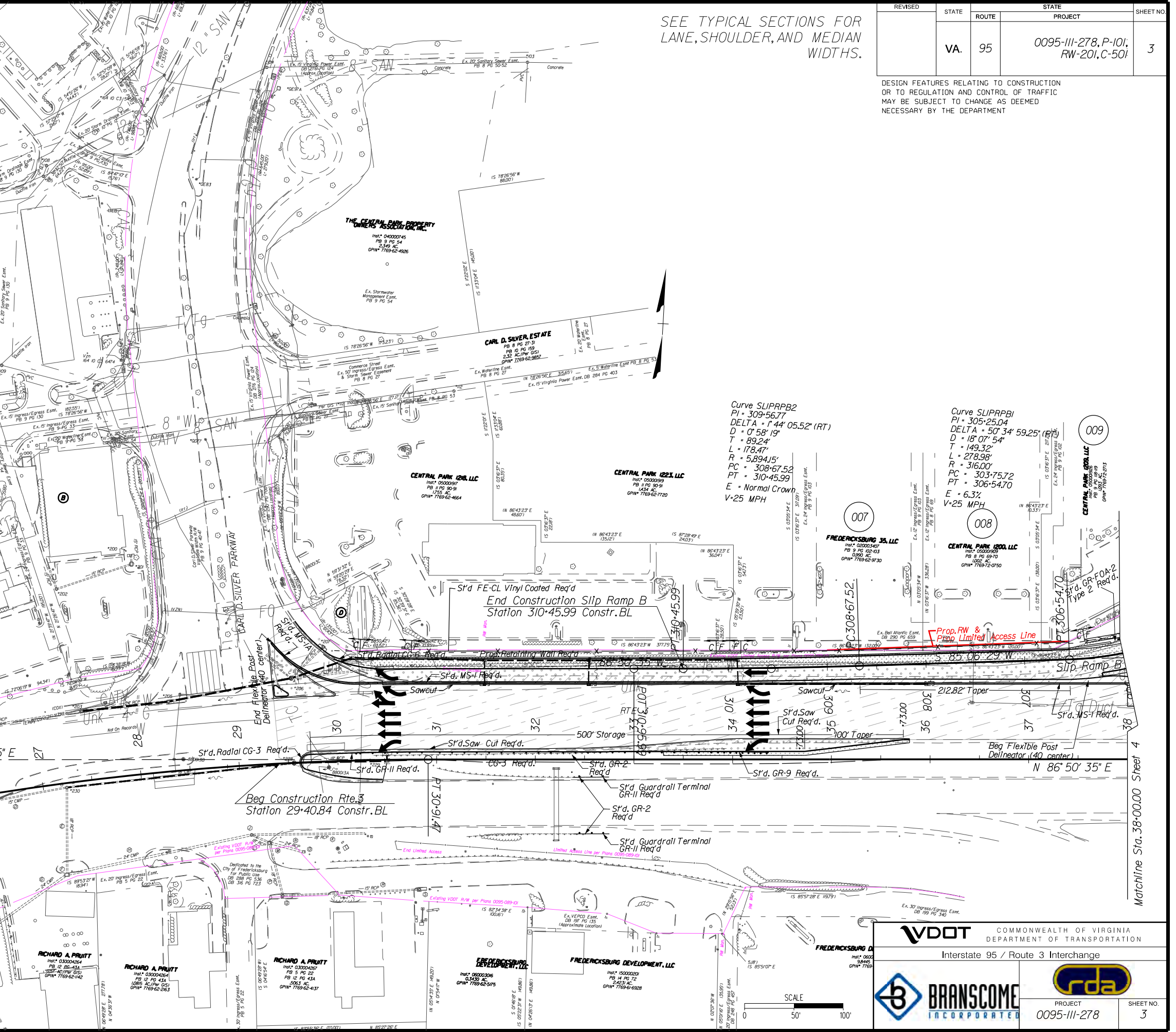

Curve SLIPRPB2
PI = 309+56.77
DELTA = 7°44'05.52" (RT)
D = 0'58"19"
T = 89.24'
L = 178.47'
R = 5,894.15'
PC = 308+67.52
PT = 310+45.99
E = Normal Crown
V=25 MPH

Curve SLIPRPB1
PI = 305+25.04
DELTA = 5°34'59.25" (RT)
D = 18'07"54"
T = 149.32'
L = 278.98'
R = 316.00'
PC = 303+75.72
PT = 306+54.70
E = 6.3%
V=25 MPH

- Denotes Survey Obscured Areas
- Denotes Construction Limits In Cuts
- Denotes Construction Limits In Fills
- Note: Figures in parenthesis and dot-dot-dashed lines denote Temporary Easements.
- Note: Figures in brackets and dot-dashed lines denote Permanent Easements.
- Denotes var. mill and overlay/build-up of existing pavement
- Denotes area of proposed pavement
- Denotes area of proposed paved shoulder
- Denotes area of obscured pavement
- Denotes area of demolition of pavement

VDOT COMMONWEALTH OF VIRGINIA
DEPARTMENT OF TRANSPORTATION

Interstate 95 / Route 3 Interchange

BRANSCOME INCORPORATED

rda

PROJECT: 0095-III-278
SHEET NO.: 3

SCALE: 0 50' 100'

Matchline Sta. 38+00.00 Sheet 4

SEE TYPICAL SECTIONS FOR LANE, SHOULDER, AND MEDIAN WIDTHS.

REVISED	STATE	ROUTE	STATE PROJECT	SHEET NO.
	VA.	95	0095-III-278, P-101, RW-201, C-501	4

DESIGN FEATURES RELATING TO CONSTRUCTION OR TO REGULATION AND CONTROL OF TRAFFIC MAY BE SUBJECT TO CHANGE AS DEEMED NECESSARY BY THE DEPARTMENT

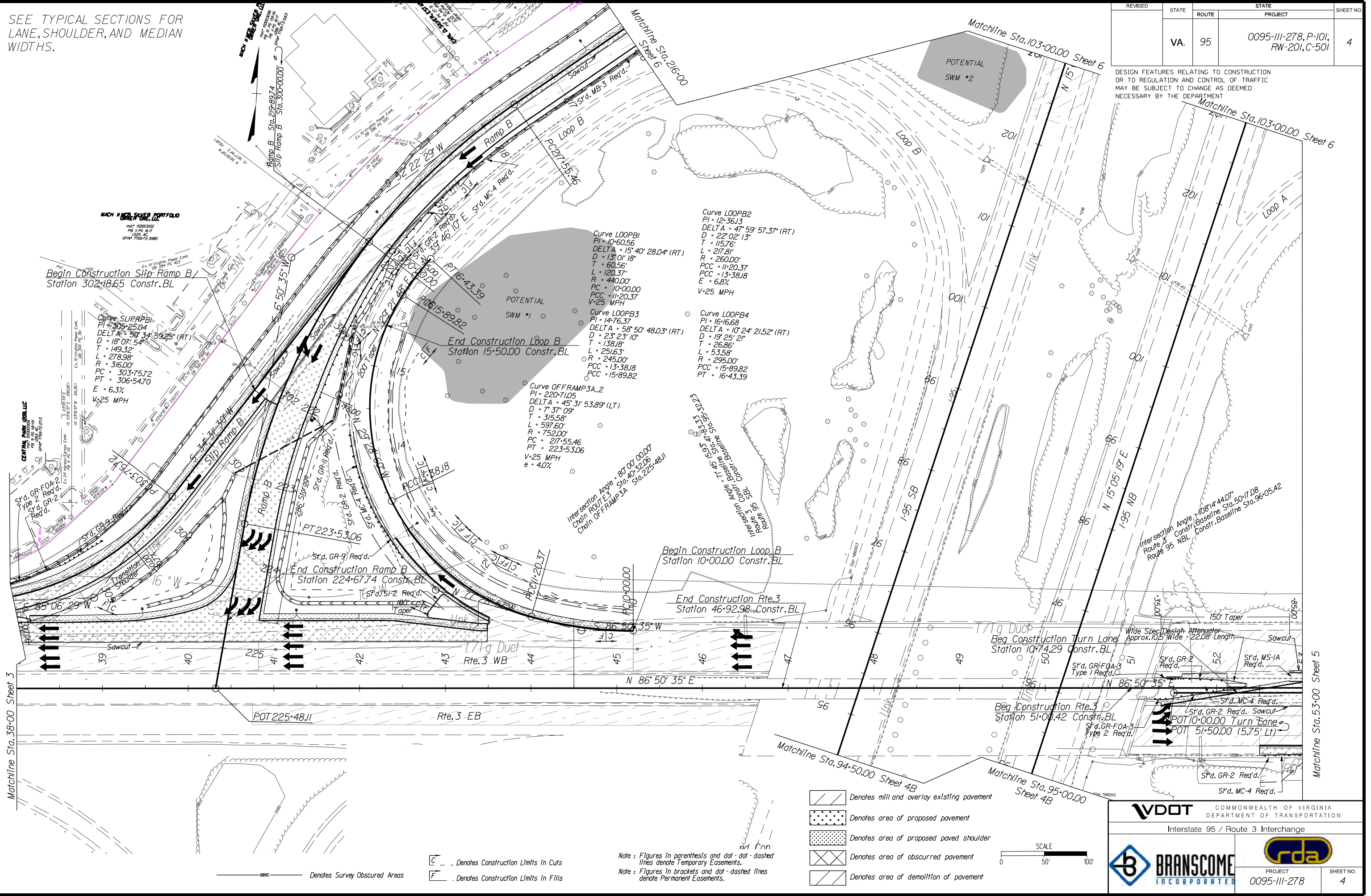

Matchline Sta. 38+00 Sheet 3

Matchline Sta. 53+00 Sheet 5

- Denotes mill and overlay existing pavement
- Denotes area of proposed pavement
- Denotes area of proposed paved shoulder
- Denotes area of obscured pavement
- Denotes area of demolition of pavement

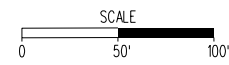

Note: Figures in parenthesis and dot - dot - dashed lines denote Temporary Easements.
Note: Figures in brackets and dot - dashed lines denote Permanent Easements.

C - Denotes Construction Limits in Cuts
F - Denotes Construction Limits in Fills

--- Denotes Survey Obscured Areas

VDOT COMMONWEALTH OF VIRGINIA
DEPARTMENT OF TRANSPORTATION

Interstate 95 / Route 3 Interchange

BRANSCOME INCORPORATED PROJECT 0095-III-278 SHEET NO. 4

Rte. 3 - EB

SEE TYPICAL SECTIONS FOR
LANE, SHOULDER, AND MEDIAN
WIDTHS.

REVISED	STATE	ROUTE	STATE PROJECT	SHEET NO.
	VA.	95	0095-III-278, P-101, RW-201, C-501	4B

DESIGN FEATURES RELATING TO CONSTRUCTION OR TO REGULATION AND CONTROL OF TRAFFIC MAY BE SUBJECT TO CHANGE AS DEEMED NECESSARY BY THE DEPARTMENT

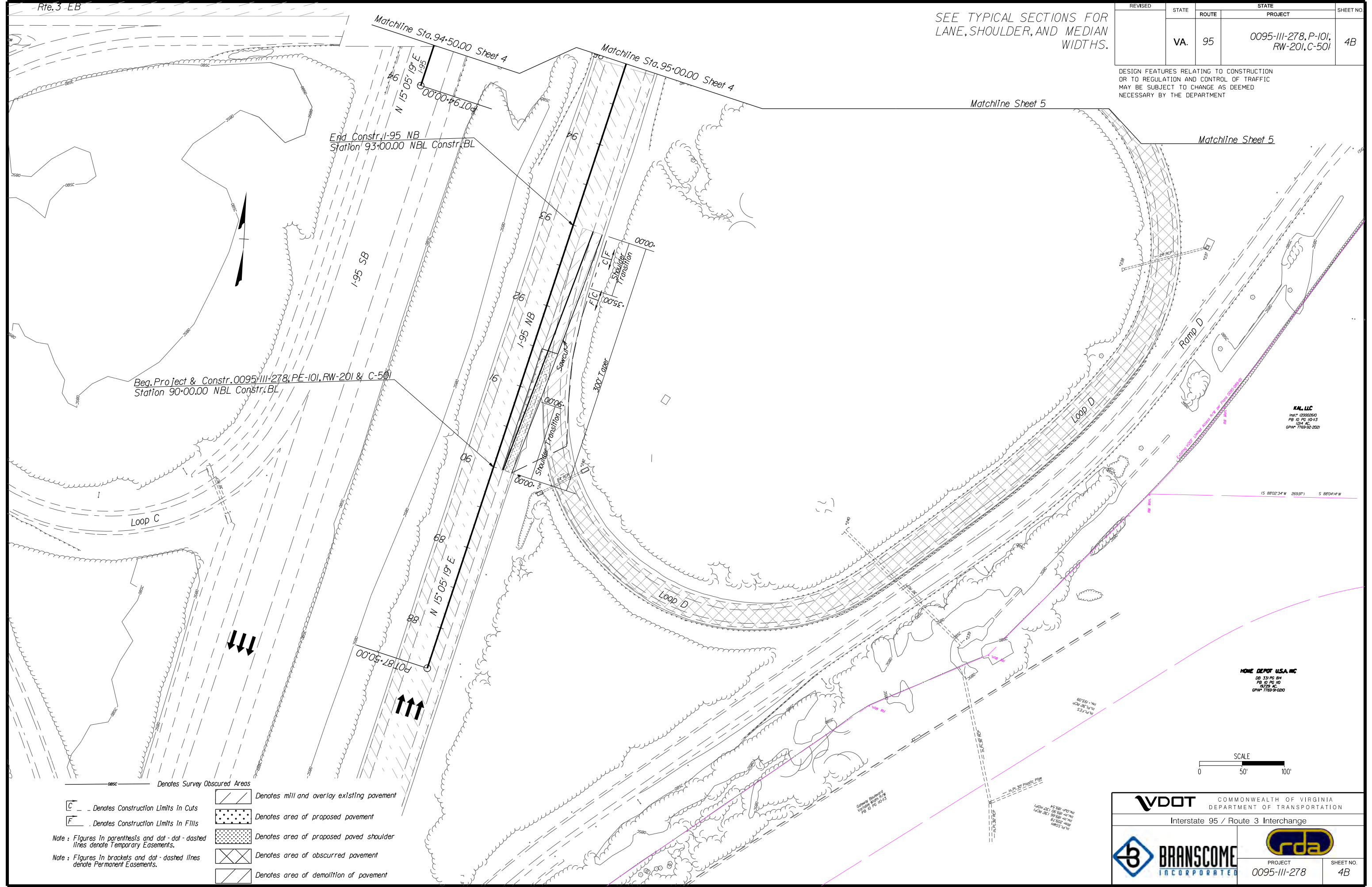

Beg. Project & Constr. Station 90+00.00 NBL Constr./BL

End Constr. I-95 NB Station 93+00.00 NBL Constr./BL

KAL, LLC
MAP 0000050
PG 10 PG 10-13
10/4 AC
GPM 7769-20-2021

HONE DEPOT USA, INC
00 331 PG 84
PG 10 PG 10
02/29 AC
GPM 7769-20-2021

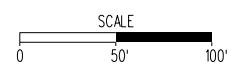

- Denotes Survey Obscured Areas
- Denotes Construction Limits In Cuts
- Denotes Construction Limits In Fills
- Note: Figures in parenthesis and dot-dot-dashed lines denote Temporary Easements.
- Note: Figures in brackets and dot-dashed lines denote Permanent Easements.
- Denotes mill and overlay existing pavement
- Denotes area of proposed pavement
- Denotes area of proposed paved shoulder
- Denotes area of obscured pavement
- Denotes area of demolition of pavement

VDOT COMMONWEALTH OF VIRGINIA
DEPARTMENT OF TRANSPORTATION

Interstate 95 / Route 3 Interchange

BRANSCOME INCORPORATED

rda

PROJECT: 0095-III-278
SHEET NO.: 4B

SEE TYPICAL SECTIONS FOR LANE, SHOULDER, AND MEDIAN WIDTHS.

REVISED	STATE	ROUTE	STATE PROJECT	SHEET NO.
	VA.	95	0095-III-278, P-101, RW-201, C-501	5

DESIGN FEATURES RELATING TO CONSTRUCTION OR TO REGULATION AND CONTROL OF TRAFFIC MAY BE SUBJECT TO CHANGE AS DEEMED NECESSARY BY THE DEPARTMENT

- Denotes mill and overlay existing pavement
- Denotes area of proposed pavement
- Denotes area of proposed paved shoulder
- Denotes area of obscured pavement
- Denotes area of demolition of pavement
- Denotes Survey Obscured Areas

- Denotes Construction Limits In Cuts
- Denotes Construction Limits In Fills
- Note: Figures in parenthesis and dot-dashed lines denote Temporary Easements.
- Note: Figures in brackets and dot-dashed lines denote Permanent Easements.

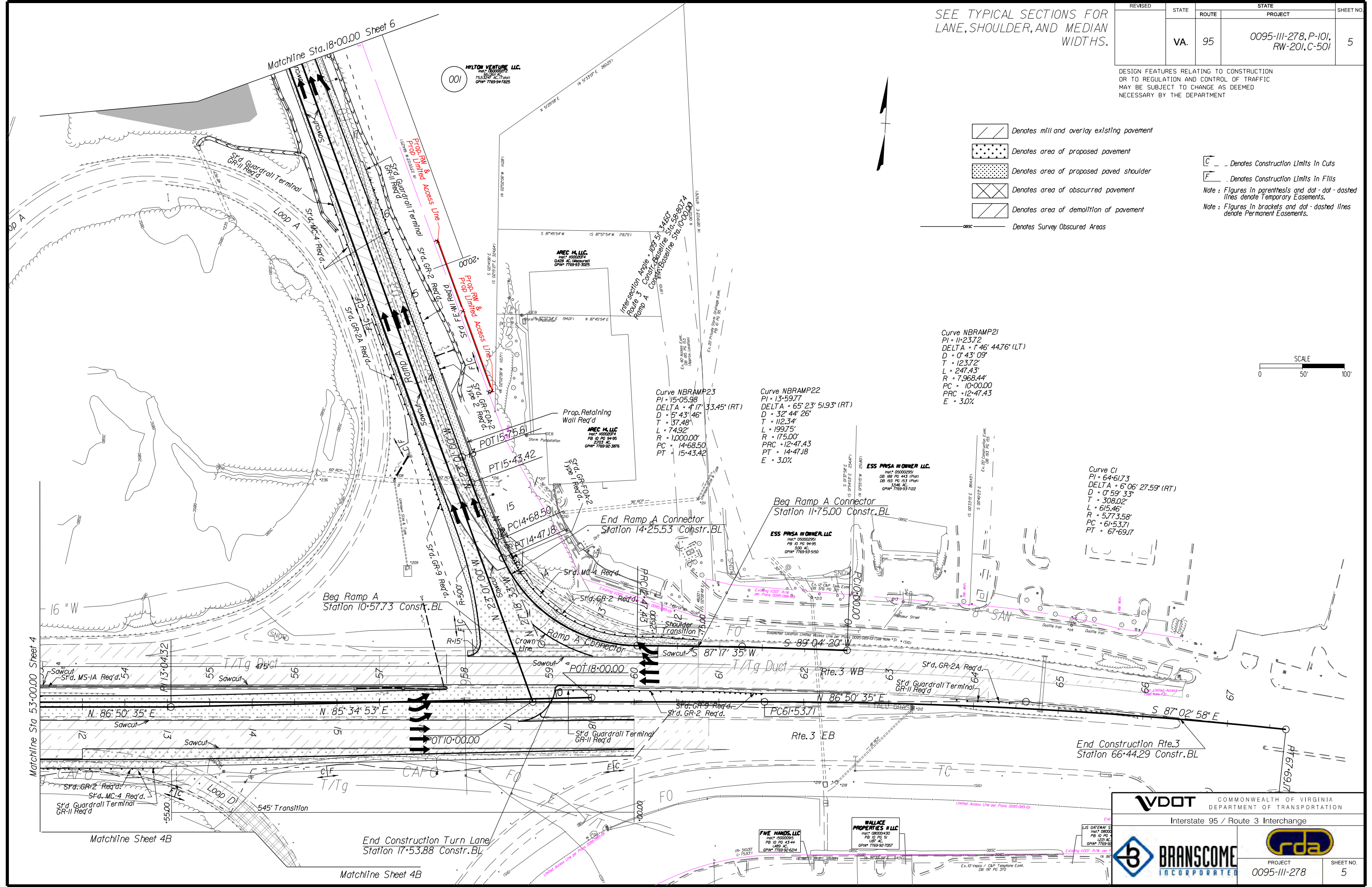
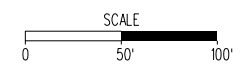

VDOT COMMONWEALTH OF VIRGINIA DEPARTMENT OF TRANSPORTATION
Interstate 95 / Route 3 Interchange

BRANSCOME INCORPORATED

PROJECT: 0095-III-278
SHEET NO.: 5

REVISED	STATE	ROUTE	PROJECT	SHEET NO.
	VA.	95	0095-III-278, P-101, RW-201, C-501	6

DESIGN FEATURES RELATING TO CONSTRUCTION OR TO REGULATION AND CONTROL OF TRAFFIC MAY BE SUBJECT TO CHANGE AS DEEMED NECESSARY BY THE DEPARTMENT

SEE TYPICAL SECTIONS FOR LANE, SHOULDER, AND MEDIAN WIDTHS.

- Denotes Construction Limits In Cuts
- Denotes Construction Limits In Fills
- Note: Figures in parenthesis and dot-dot-dashed lines denote Temporary Easements.
- Note: Figures in brackets and dot-dashed lines denote Permanent Easements.
- Denotes Survey Obscured Areas
- Denotes area of proposed pavement
- Denotes area of proposed paved shoulder
- Denotes area of demolition of pavement
- Denotes mill and overlay existing pavement
- Denotes area of obscured pavement

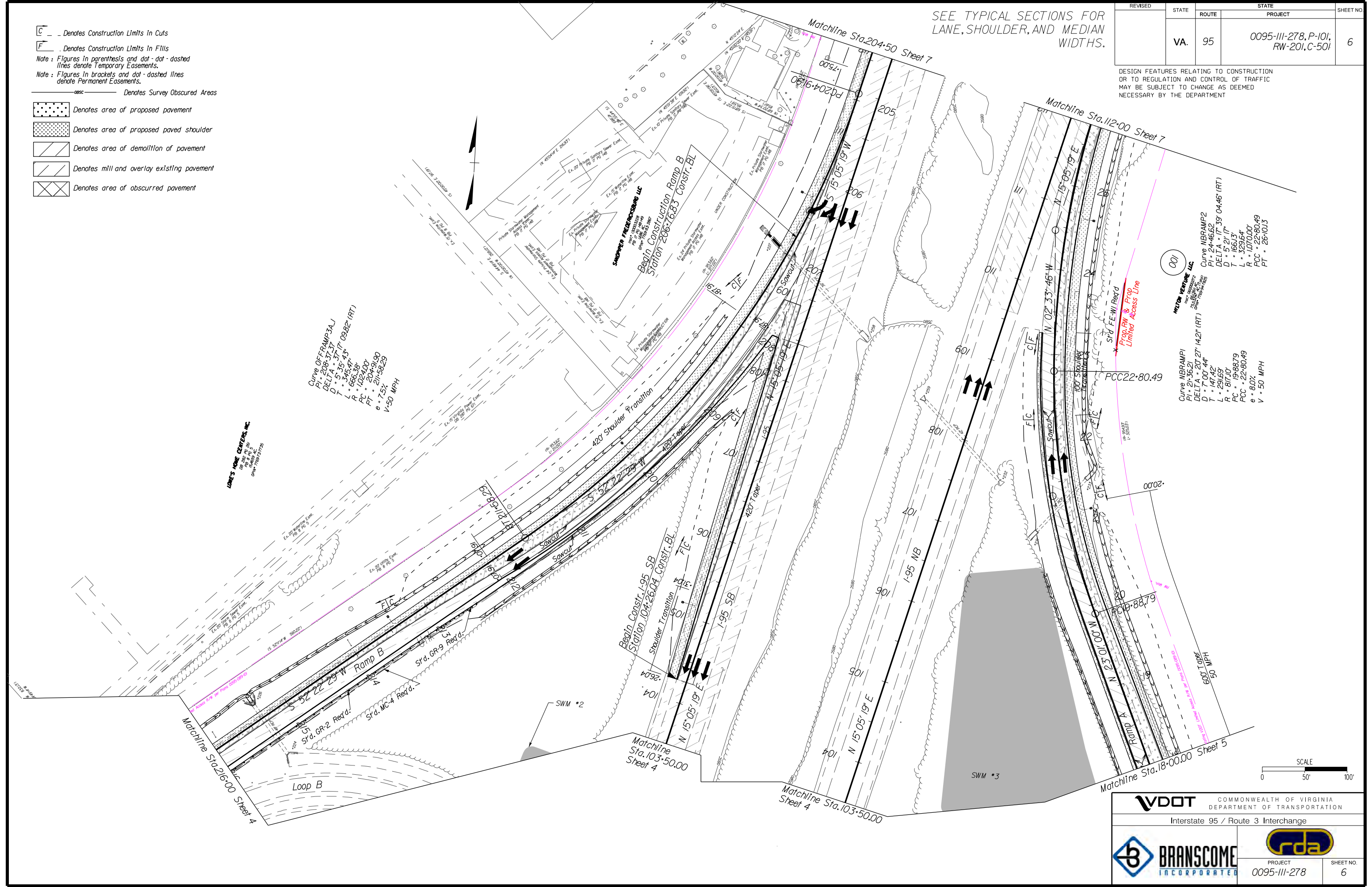

Curve OFFRAMP3AJ
PI = 208+37.37
DELTA = 37° 17' 09.88" (RT)
D = 5+35+71.7
L = 345.47
R = 666.38
PC = 102+107
PT = 204+91.90
e = 7.5%
V = 50 MPH

LOWE'S HOME CENTERS, INC.
10000 W. 10th St.
Farmingdale, NY 11735
909-7788-7125

SWANPER FURNACEWORKS LLC
10000 W. 10th St.
Farmingdale, NY 11735
909-7788-7125

Curve NBRAMP2
PI = 24+46.62
DELTA = 17° 39' 04.46" (RT)
D = 5+21+17
L = 166.13
R = 329.64
PC = 22+80.49
PT = 26+101.3
V = 50 MPH

Curve NBRAMP1
PI = 21+36.21
DELTA = 20° 27' 14.21" (RT)
D = 7+00+44
L = 147.42
R = 291.69
PC = 19+88.79
PT = 22+80.49
e = 8.0%
V = 50 MPH

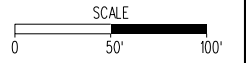

VDOT COMMONWEALTH OF VIRGINIA
DEPARTMENT OF TRANSPORTATION

Interstate 95 / Route 3 Interchange

BRANSCOME INCORPORATED

rda

PROJECT: 0095-III-278
SHEET NO.: 6

SEE TYPICAL SECTIONS FOR
LANE, SHOULDER, AND MEDIAN
WIDTHS.

REVISED	STATE	ROUTE	STATE PROJECT	SHEET NO.
	VA.	95	0095-III-278, P-101, RW-201, C-501	7

DESIGN FEATURES RELATING TO CONSTRUCTION OR TO REGULATION AND CONTROL OF TRAFFIC MAY BE SUBJECT TO CHANGE AS DEEMED NECESSARY BY THE DEPARTMENT

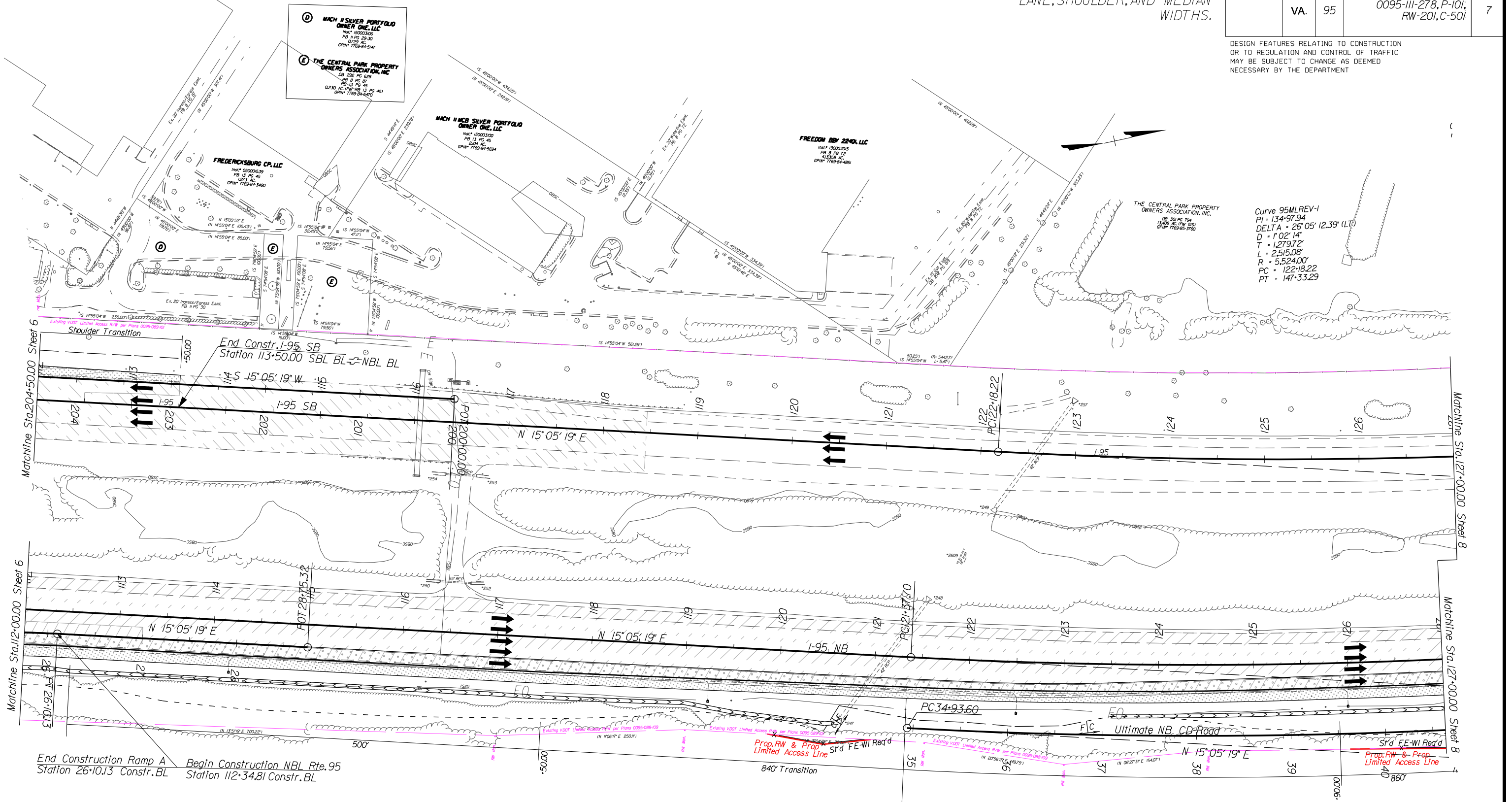

Curve 95MLREV-1
 PI = 134+97.94
 DELTA = 26° 05' 12.39" (LT)
 D = 1' 02' 14"
 T = 127' 9.72'
 L = 2,515.08'
 R = 5,524.00'
 PC = 122+18.22
 PT = 147+33.29

End Construction Ramp A
 Station 26+10.13 Constr. BL

Begin Construction NBL Rte.95
 Station 112+34.81 Constr. BL

- obsc — Denotes Survey Obscured Areas
- Denotes mill and overlay existing pavement
- Denotes area of proposed pavement
- Denotes area of proposed paved shoulder
- Denotes area of demolition of pavement
- Denotes area of obscured pavement

C — Denotes Construction Limits In Cuts
F — Denotes Construction Limits In Fills
 Note: Figures in parenthesis and dot-dot-dashed lines denote Temporary Easements.
 Note: Figures in brackets and dot-dashed lines denote Permanent Easements.

001
 HILTON VENTURE LLC
 75.6 824 AL 11 dnd
 GPN# 7769-94-7825

Ultimate CD-Road
 Curve CDWALL22
 PI = 41+22.02
 DELTA = 12° 39' 35.70" (LT)
 D = 1' 00' 4"
 T = 628.42'
 L = 1,251.72'
 R = 5,665.00'
 PC = 34+93.60
 PCC = 47+45.32

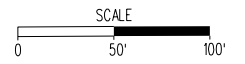

Curve 95NB2

VDOT COMMONWEALTH OF VIRGINIA
 DEPARTMENT OF TRANSPORTATION

Interstate 95 / Route 3 Interchange

BRANSCOME INCORPORATED

PROJECT: 0095-III-278
 SHEET NO.: 7

- WL-- Denotes Wetland Limits
- ossc Denotes Survey Obscured Areas
- Denotes mill and overlay existing pavement
- Denotes area of proposed pavement
- Denotes area of proposed paved shoulder
- Denotes area of demolition of pavement
- Denotes area of obscured pavement

SEE TYPICAL SECTIONS FOR LANE, SHOULDER, AND MEDIAN WIDTHS.

REVISED	STATE	ROUTE	STATE PROJECT	SHEET NO.
	VA.	95	0095-III-278, P-101, RW-201, C-501	8

DESIGN FEATURES RELATING TO CONSTRUCTION OR TO REGULATION AND CONTROL OF TRAFFIC MAY BE SUBJECT TO CHANGE AS DEEMED NECESSARY BY THE DEPARTMENT

Curve 95NB2
 PI = 134+27.46
 DELTA = 25° 59' 04.76" (LT)
 D = 1' 01' 30"
 T = 1289.76'
 L = 2,535.16'
 R = 5,590.00'
 PC = 121+37.70
 PT = 146+72.86

Curve 95MLREV-1
 PI = 134+97.94
 DELTA = 26° 05' 12.39" (LT)
 D = 1' 02' 14"
 T = 1279.72'
 L = 2,515.08'
 R = 5,524.00'
 PC = 122+18.22
 PT = 147+33.29

THE CENTRAL PARK PROPERTY OWNERS ASSOCIATION, INC.
 DE 30 PS 794
 13402 AC (Per 95)
 GPN# 7769-95-3760

THE CONTRARY CREEK COMPANY CORP., LLC
 INST# 070002173
 PB # 23-24
 10000 AC (Per 95)
 GPN# 7769-95-954

NELSON A GRAVES, JR. & JOYCE D GRAVES
 DE 164 PS 474
 34200 AC (Per 95)
 GPN# 7769-16-1037

GLORIA B WHITNER, CAROL B COLEMAN & EDWINE B CARTER
 DE 208 PS 100
 20400 AC (Per 95)
 GPN# 7769-01-3229

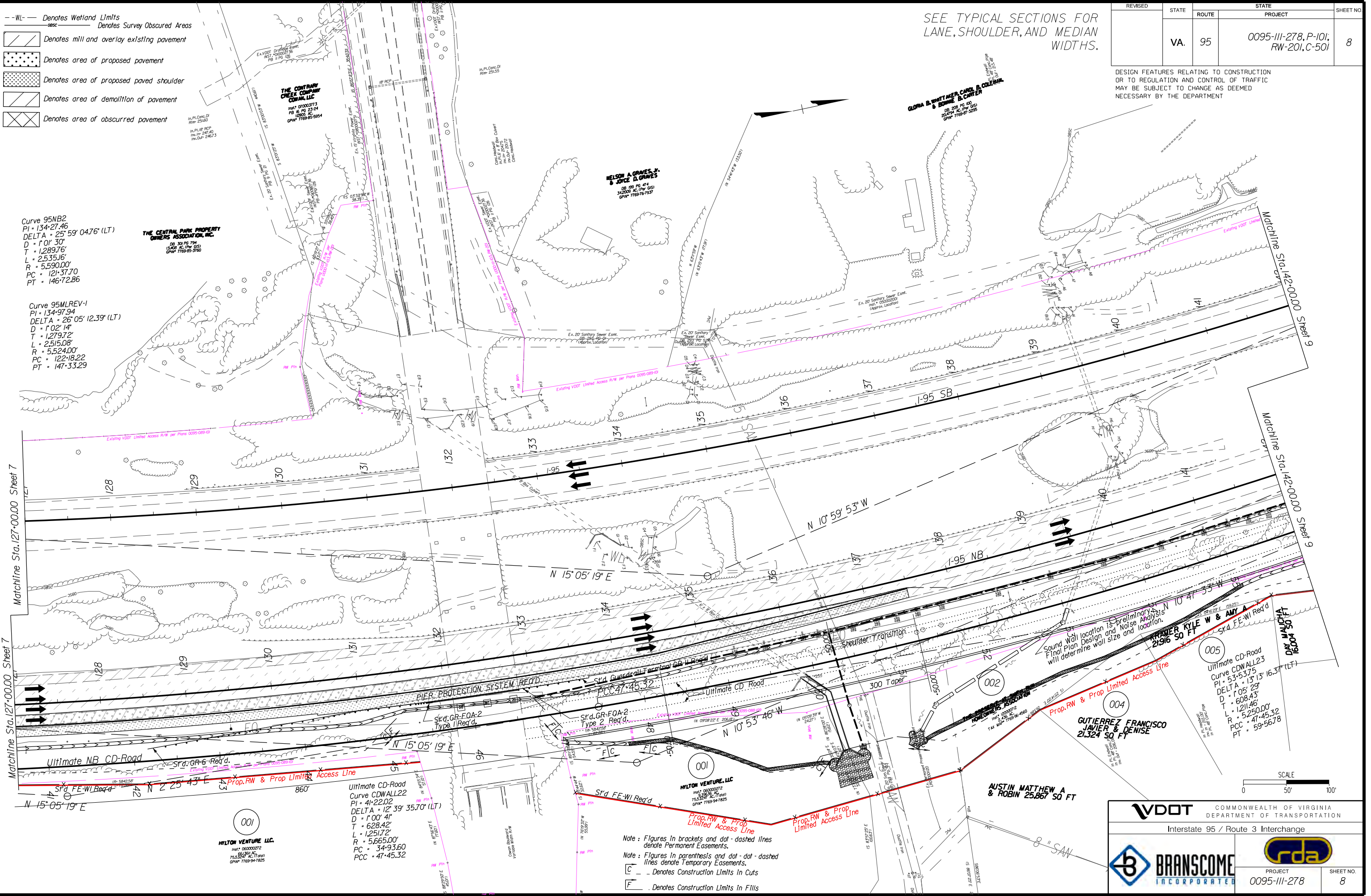

Matchline Sta. 127+00.00 Sheet 7

Matchline Sta. 127+00.00 Sheet 7

Matchline Sta. 142+00.00 Sheet 9

Matchline Sta. 142+00.00 Sheet 9

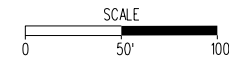

VDOT COMMONWEALTH OF VIRGINIA
 DEPARTMENT OF TRANSPORTATION
 Interstate 95 / Route 3 Interchange

BRANSCOME INCORPORATED

PROJECT: 0095-III-278
 SHEET NO.: 8

Note: Figures in brackets and dot-dashed lines denote Permanent Easements.
 Note: Figures in parenthesis and dot-dot-dashed lines denote Temporary Easements.
 [C] Denotes Construction Limits in Cuts
 [F] Denotes Construction Limits in Fills

SEE TYPICAL SECTIONS FOR
LANE, SHOULDER, AND MEDIAN
WIDTHS.

REVISED	STATE	ROUTE	PROJECT	SHEET NO.
	VA.	95	0095-III-278, P-101, RW-201, C-501	9

DESIGN FEATURES RELATING TO CONSTRUCTION OR TO REGULATION AND CONTROL OF TRAFFIC MAY BE SUBJECT TO CHANGE AS DEEMED NECESSARY BY THE DEPARTMENT

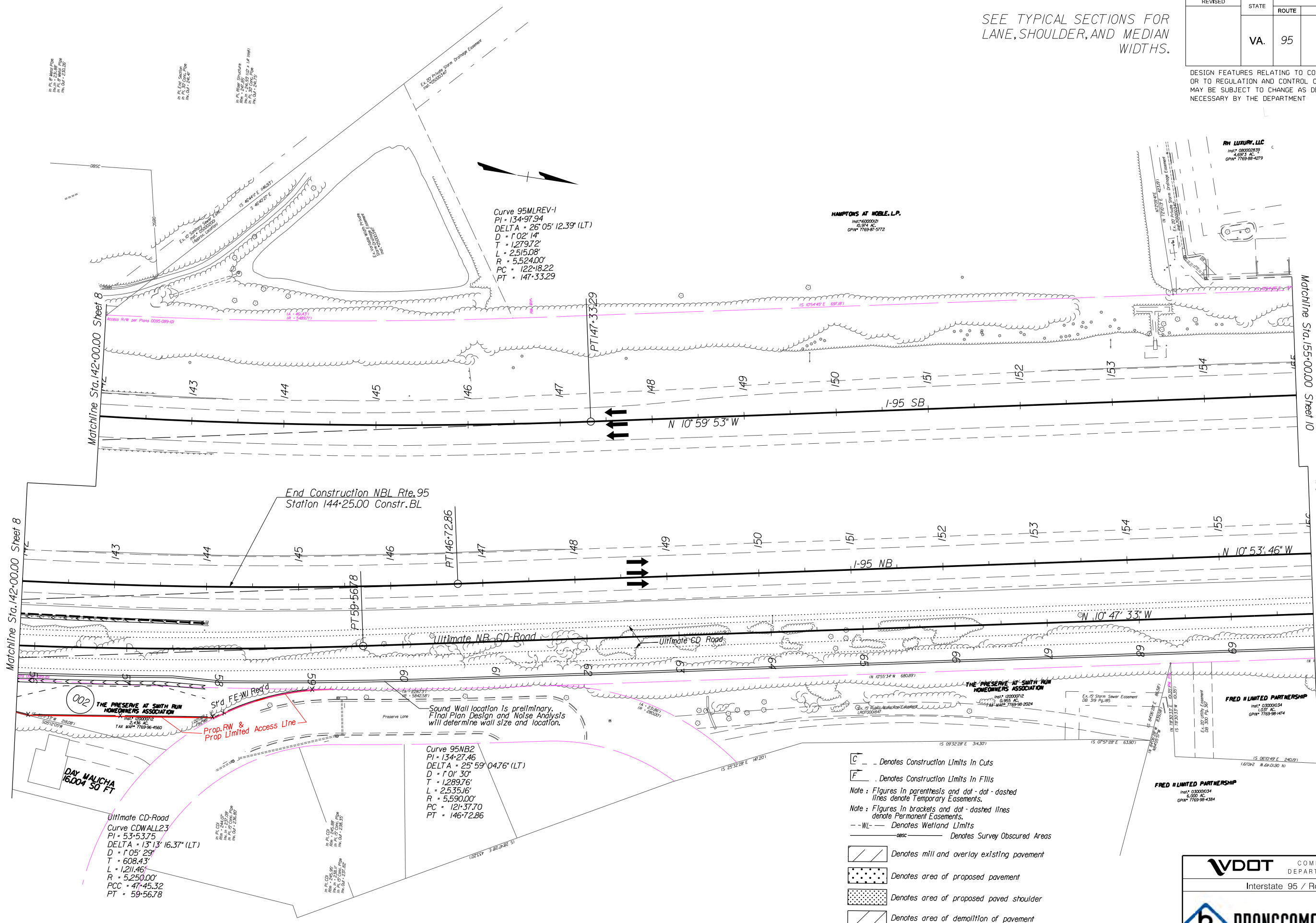

- Denotes Construction Limits in Cuts
- Denotes Construction Limits in Fills
- Note: Figures in parenthesis and dot-dot-dashed lines denote Temporary Easements.
- Note: Figures in brackets and dot-dashed lines denote Permanent Easements.
- WL-- Denotes Wetland Limits
- obs - Denotes Survey Obscured Areas
- Denotes mill and overlay existing pavement
- Denotes area of proposed pavement
- Denotes area of proposed paved shoulder
- Denotes area of demolition of pavement
- Denotes area of obscured pavement

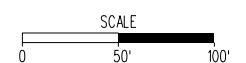

VDOT COMMONWEALTH OF VIRGINIA
 DEPARTMENT OF TRANSPORTATION

Interstate 95 / Route 3 Interchange

BRANSCOME INCORPORATED

PROJECT: 0095-III-278
 SHEET NO.: 9

REVISED	STATE	ROUTE	PROJECT	SHEET NO.
	VA.	95	0095-III-278, P-101, RW-201, C-501	10

DESIGN FEATURES RELATING TO CONSTRUCTION OR TO REGULATION AND CONTROL OF TRAFFIC MAY BE SUBJECT TO CHANGE AS DEEMED NECESSARY BY THE DEPARTMENT

SEE TYPICAL SECTIONS FOR LANE, SHOULDER, AND MEDIAN WIDTHS.

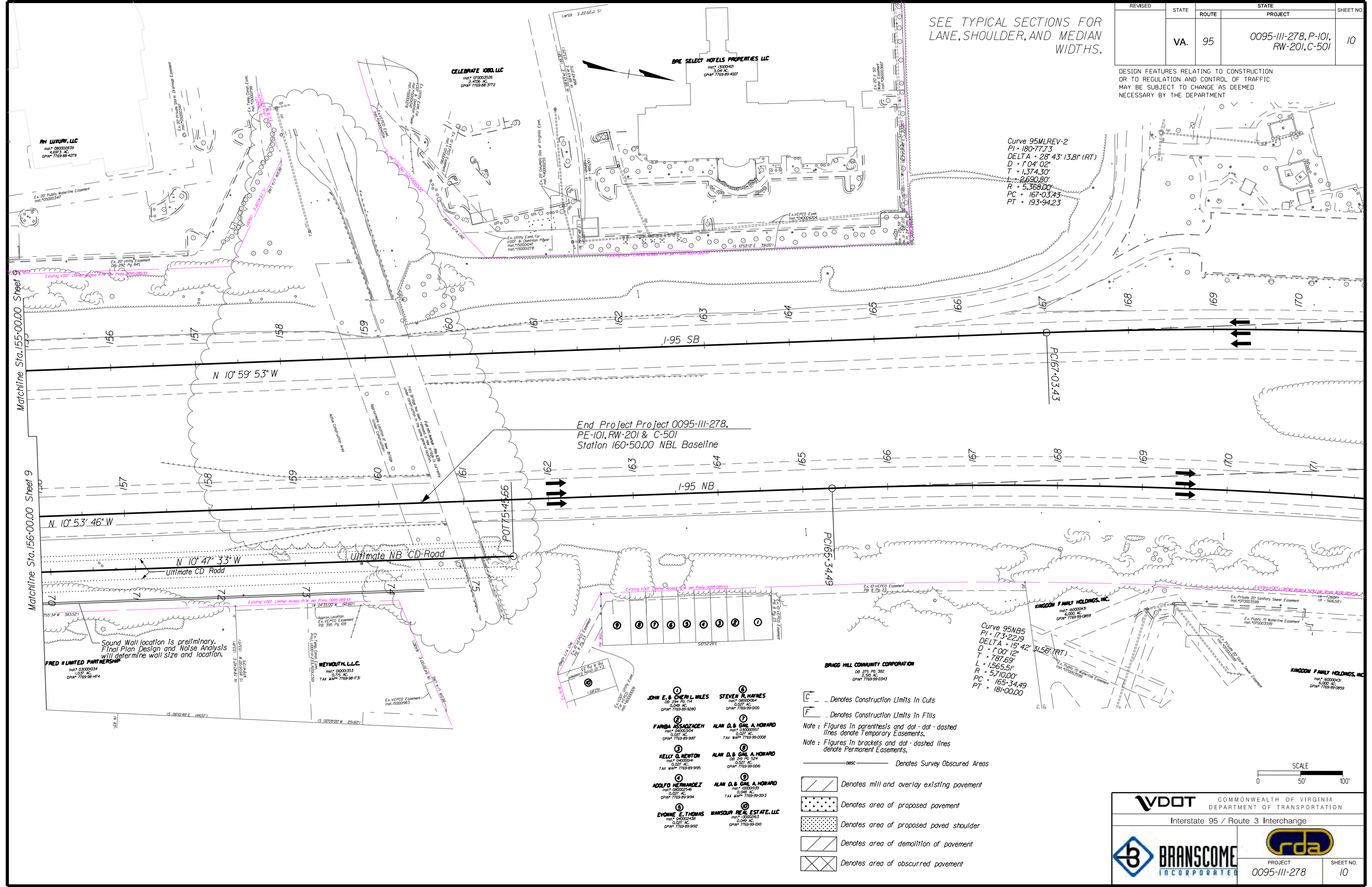

End Project Project 0095-III-278,
PE-101, RW-201 & C-501
Station 160+50.00 NBL Baseline

Curve 95MLREV-2
PI = 180+77.73
DELTA = 28° 43' 13.81" (RT)
D = 1' 04' 02"
T = 1,374.30'
L = 2,690.80'
R = 5,368.00'
PC = 167+03.43
PT = 193+94.23

Curve 95NB5
PI = 173+22.19
DELTA = 15° 42' 31.56" (RT)
D = 1' 00' 12"
T = 787.69'
L = 1,565.51'
R = 5,710.00'
PC = 165+34.49
PT = 181+00.00

- ① JOHN E. & CHERYL MILES
Inst: 08200154
0.048 AC
GPN# 7769-99-9280
- ② FARBA ASSAZADEH
Inst: 04000304
0.027 AC
GPN# 7769-99-9187
- ③ KELLY D. NEWTON
Inst: 08000394
0.027 AC
TAX MAP# 7769-99-9195
- ④ ADOLFO HERNANDEZ
Inst: 08000246
0.048 AC
GPN# 7769-99-9194
- ⑤ EVHINE E. THOMAS
Inst: 04000348
0.027 AC
GPN# 7769-99-9192
- ⑥ STEVEN R. HAYNES
Inst: 08000104
0.027 AC
GPN# 7769-99-9100
- ⑦ ALAN D. & GAIL A. HOWARD
Inst: 03000297
0.027 AC
TAX MAP# 7769-99-0008
- ⑧ ALAN D. & GAIL A. HOWARD
Inst: 08000394
0.027 AC
GPN# 7769-99-0006
- ⑨ ALAN D. & GAIL A. HOWARD
Inst: 03000139
0.048 AC
TAX MAP# 7769-99-0003
- ⑩ MAHSAUR REAL ESTATE, LLC
Inst: 13000263
0.048 AC
GPN# 7769-99-1000

- C - Denotes Construction Limits In Cuts
- F - Denotes Construction Limits In Fills
- Note: Figures in parenthesis and dot-dot-dashed lines denote Temporary Easements.
- Note: Figures in brackets and dot-dashed lines denote Permanent Easements.
- obsc----- Denotes Survey Obscured Areas
- [Hatched] Denotes mill and overlay existing pavement
- [Dotted] Denotes area of proposed pavement
- [Cross-hatched] Denotes area of proposed paved shoulder
- [Diagonal lines] Denotes area of demolition of pavement
- [X-hatched] Denotes area of obscured pavement

Sound Wall location is preliminary.
Final Plan Design and Noise Analysis
will determine wall size and location.

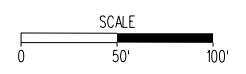

VDOT COMMONWEALTH OF VIRGINIA
DEPARTMENT OF TRANSPORTATION

Interstate 95 / Route 3 Interchange

PROJECT 0095-III-278 SHEET NO. 10

BRANSCOME INCORPORATED

rdc

PRICE PROPOSAL



A DESIGN-BUILD PROJECT

I-95 Safety Improvements at Route 3

From: 0.115 Miles South of Int. Route 3 To: 1.220 Miles North of Int. Route 3
City of Fredericksburg, Virginia

Submitted to:
Virginia Department of Transportation



State Project No.: 0095-111-278
Federal Project No.: OC-095-2(535)
Contract ID Number: C00107715DB91

SOLICITATION DB 107715B

Submitted by:
Branscome Incorporated
in association with Rinker Design Associates, P.C.



January 4, 2017

ATTACHMENT 4.0.1.2

**DESIGN-BUILD PRICE PROPOSAL
CHECKLIST**

**Project Name: I-95 Safety Improvements at Route 3
Contract ID Number: C00107715DB91**

➤ **Contents of Price Proposal:**

- Cost Breakdown Summary in whole numbers and the Proposal Price, in both numbers and words (Attachment 4.3.1)**
 - Price Adjustment Information and Forms for Fuel, Asphalt and Steel, including identification of pay items and associated quantities eligible for adjustment (Part 3, Section 6.3, Attachments 6.3)**
 - Proposal Guaranty (C-24) required by Section 102.07 of Part 5, Division I Amendments to the Standard Specifications**
 - Sworn Statement Forms (C-104, C-105, Attachments 4.3.4(a) and 4.3.4(b))**
 - CD-ROM containing the entire Price Proposal in a single cohesive Adobe PDF file**
-

4.3.1 Cost Breakdown Summary and Proposal Price

ATTACHMENT 4.3.1

PRICE PROPOSAL FORM

4.8.1 Offeror shall specify the pricing information for the items below, the dollars amount shall be in whole numbers:

Price Proposal Cost Breakdown Summary;

A. Base Scope

Design Services, LS	\$ 1,400,000. ⁰⁰
Construction Services (exclude QA/QC), LS	\$ 12,860,000. ⁰⁰
Quality Assurance (QA) (Construction), LS	\$ 726,000. ⁰⁰
Quality Control (QC) (Construction), LS	\$ 668,000. ⁰⁰
All Other Costs, LS	\$ 1,676,000. ⁰⁰
Base Scope – Subtotal	\$ 17,330,000. ⁰⁰

B. Option 1

Design Services, LS	\$ 120,600. ⁰⁰
Construction Services (exclude QA/QC), LS	\$ 3,727,000. ⁰⁰
Quality Assurance (QA) (Construction), LS	\$ 80,600. ⁰⁰
Quality Control (QC) (Construction), LS	\$ 74,900. ⁰⁰
All Other Costs, LS	\$ 261,400. ⁰⁰
Option 1 – Subtotal	\$ 4,264,500. ⁰⁰

Total Proposal Price (Base Scope Subtotal + Option 1 Subtotal); (Specify the Total Lump Sum price in both numbers and words, this price shall **equal** to the total sum of the items listed above)

Lump Sum (LS): TWENTY-ONE MILLION, FIVE HUNDRED AND
NINETY-FOUR THOUSAND, FIVE HUNDRED DOLLARS. (\$ 21,594,500.⁰⁰)

Signature:  Date: JANUARY 4, 2017

Design-Builder: BRANSCOME INC.

Vendor No.: 13850

4.3.2 Price Adjustment Information & Forms for Fuel, Asphalt, & Steel

Exhibit 6.3(b)

Form C-16a
August 9, 2013

**COMMONWEALTH OF VIRGINIA
DEPARTMENT OF TRANSPORTATION
ASPHALT PRICE ADJUSTMENT (PG76-22 or PG 70-28)
DESIGN-BUILD PROJECTS**

INSTRUCTIONS - This form is to be completed and returned ONLY when asphalt concrete items containing PG 76-22 or PG 70-28 is being utilized on the project.

PROJECT NUMBER:

DISTRICT:

Bid Prices in this contract for items containing PG 76-22 or PG 70 asphalt cement were developed using a f.o.b. price of \$ 466.43 Per **IMPERIAL** ton for PG 76-22 or PG 70-28. This quote is project specific.

Price quotes signed by each supplier from which the Design-Builder proposes to obtain PG 76-22 or PG 70-28 shall be maintained by the Design-Builder. These quotes shall be retained on site during the life of the Contract for review by the Engineer upon request.

DATE: January 4, 2017

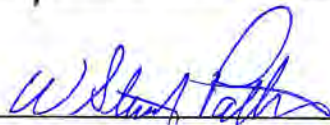
SIGNATURE: 

BRANSCOME INC.
(Firm or Corporation)

B850
(Vendor No.)

**EXHIBIT 6.3 (c)
ADJUSTMENT FOR FUEL**

**VIRGINIA DEPARTMENT OF TRANSPORTATION
SPECIAL PROVISION FOR
OPTIONAL ADJUSTMENT FOR FUEL
DESIGN-BUILD PROJECTS**

June 30, 2011

In the event the Design-Builder elects to seek adjustment for fuel items designated in the Price Proposal/Contract as Price Adjustment Items such items will be subject to price adjustment as set forth herein. Other items will not be adjusted, except as otherwise specified in the contract.

The Design-Builder will submit their monthly application for payment associated with eligible work packages with an adjustment up or down as appropriate for cost changes in fuel used on specific items of work identified in this provision. A master listing of standard items eligible for fuel adjustment is provided by the Department on its website at the following link <http://www.virginiadot.org/business/resources/masteroptionalfuelitems.pdf>. The listing on the web site also includes the corresponding fuel factor for each item. The fuel usage factor for each item is considered inclusive of all fuel usage.

The amount of adjustment will be computed from the change in the indexes and the on-site fuel use as shown in the Department's master listing of eligible items.

In order to be eligible for fuel adjustment under this provision, the Design-Builder shall clearly identify in within the Schedule of Values those pay items and the associated quantities it chooses to have fuel adjustment applied to in its work packages. Items the Design-Builder claims in its application of payment for fuel adjustments must be properly designated in order to be considered for adjustment. Items not properly designated or left out of the Design-Builder's Schedule of Values will automatically not be considered for adjustment.

The monthly index price to be used in the administration of this provision will be calculated by the Department from the Diesel fuel prices published by the U. S. Department of Energy, Energy Information Administration on highway diesel prices, for the Lower Atlantic region. The monthly index price will be the price for diesel fuel calculated by averaging each of the weekly posted prices for that particular month.

For the purposes of this provision, the base index price will be calculated using the data from the month preceding the receipt of bids. The base index price will be posted by the Department at the beginning of the month for all bids received during that month.

The current index price will be posted by the Department and will be calculated using the data from the month preceding the particular estimate being vouchered for payment.

The current monthly quantity for eligible items of work selected by the Design-Builder for fuel adjustment in its work packages will be multiplied by the appropriate fuel factor to determine the gallons of fuel to be cost adjusted. The amount of adjustment per gallon will be the net difference between the current index price and the base index price. Computation for adjustment will be made as follows:

$$S = (E - B) QF$$

Where; S = Monetary amount of the adjustment (plus or minus)

B = Base index price

E = Current index price

Q = Quantity of individual units of work

F = Appropriate fuel factor

Adjustments will not be made for work performed beyond the original contract time limit unless the original time limit has been changed by an executed Work Order.

If new pay items are added to this contract by Work Order and they are listed in the Department's master listing of eligible items, the Work Order must indicate which of these individual items will be fuel adjusted; otherwise, those items will not be fuel adjusted. If applicable, designating which new pay items will be added for fuel adjustment must be determined during development of the Work Order and clearly shown on the Work Order form. The Base Index price on any new eligible pay items added by Work Order will be the Base Index price posted for the month in which bids were received for that particular project. The Current Index price for any new eligible pay items added by Work Order will be the Index price posted for the month preceding the estimate on which the Work Order is paid.

When quantities differ between the last monthly application of payment prepared upon final acceptance and the final application of payment, adjustment will be made using the appropriate current index for the period in which that specific item of work was last performed.

In the event any of the base fuel prices in this contract increase more than 100 percent (i.e. fuel prices double), the Department will review each affected item of work and give the Design-Builder written notice if work is to stop on any affected item of work. The Department reserves the right to reduce, eliminate or renegotiate the price for remaining portions of affected items of work.

Any amounts resulting from fuel adjustment will not be included in the total cost of work for determination of progress or for extension of contract time.

I elect to use this provision

I elect not to use this provision

Date: January 4, 2017

Signature: 

Design-Builder: BRANSCOME INC.

Vendor No.: B850

**COMMONWEALTH OF VIRGINIA
DEPARTMENT OF TRANSPORTATION
PROPOSAL GUARANTY**

KNOW ALL MEN BY THESE PRESENTS, THAT WE Branscome, Inc. As principal, and Liberty Mutual Insurance Company Surety, are held and firmly bound unto the Commonwealth of Virginia as obligee, in the amount of FIVE PERCENT OF THE DOLLAR VALUE OF THE BID, lawful money of the United States of America, for the payment of which, well and truly to be made, we bind ourselves, our heirs, executors, administrators, successors and assigns, jointly and severally and firmly by these presents.

SIGNED, sealed and dated this 4th Day of January, 2017

WHEREAS, the above said principal is herewith submitting its proposal for:

PROJECT NUMBER: 0095-111-278

I-95 Safety Improvements at Route 3, from 0.115 Miles South of Int. Route 3 to 1.220 Miles North of Int. Route 3, City of Fredericksburg, Virginia

NOW, THEREFORE, the condition of the above obligee is such, that if the aforesaid principal shall be awarded the contract upon said proposal and shall within the time specified in the Specifications after the notice of such award enter into a contract and give bond for the faithful performance of the contract, then this obligation shall be null and void; otherwise to remain in full force and effect and the principal and surety will pay unto the obligee the difference in money between the amount of the bid of the said principal and the amount for which the obligee may legally contract with another party to perform the said work if the latter amount be in excess of the former; but in no event shall the liability exceed the penal sum hereof.

Branscome, Inc.

(Principal*)

By: [Signature]
(Officer, Partner or Owner) (Seal)

(Principal*)

By: _____
(Officer, Partner or Owner) (Seal)

(Principal*)

By: _____
(Officer, Partner or Owner) (Seal)

Liberty Mutual Insurance Company

(Surety Company)

By: [Signature]
Wendy Lee Wadkins (Attorney-in-Fact**) (Seal)
175 Berkeley Street
Boston, MA 02116

(Address)

By: _____
(Surety Company)

(Attorney-in-Fact**) (Seal)

By: _____
(Address)



*Note: If the principal is a joint venture, each party thereof must be named and execution made by same hereon. If there is more than one surety to the bid bond, each surety must be named and execution shall be made by same hereon.

Electronic Bid Only: In lieu of completing the above section of the Contract Performance Bond, the Principal shall file an Electronic Bid Bond when bidding electronically. By signing below the Principal is ensuring the identified electronic bid bond has been executed and the Principal and Surety are firmly bound unto the Commonwealth of Virginia under the same conditions of the bid bond as shown above.

Electronic Bid Bond ID# _____ Company/Bidder Name _____ Signature and Title _____

**Attach copy of Power of Attorney

This Power of Attorney limits the acts of those named herein, and they have no authority to bind the Company except in the manner and to the extent herein stated. Not valid for mortgage, note, loan, letter of credit, bank deposit, currency rate, interest rate or residual value guarantees. To confirm the validity of this Power of Attorney call 610-832-8240 between 9:00 am and 4:30 pm EST on any business day.

Liberty Mutual Insurance Company
The Ohio Casualty Insurance Company
West American Insurance Company

POWER OF ATTORNEY

KNOWN ALL PERSONS BY THESE PRESENTS: That The Ohio Casualty Insurance Company is a corporation duly organized under the laws of the State of New Hampshire, that Liberty Mutual Insurance Company is a corporation duly organized under the laws of the State of Massachusetts, and West American Insurance Company is a corporation duly organized under the laws of the State of Indiana (herein collectively called the "Companies"), pursuant to and by authority herein set forth, does hereby name, constitute and appoint, **Wendy Lee Wadkins**

of the city of Radnor, state of PA its true and lawful attorney-in-fact, with full power and authority hereby conferred to sign, execute and acknowledge the following surety bond:

Principal Name: Branscome, Inc.

Obligee Name: Commonwealth of Virginia, Department of Transportation

Surety Bond Number: Bid Bond

Bond Amount: See Bond Form

IN WITNESS WHEREOF, this Power of Attorney has been subscribed by an authorized officer or official of the Companies and the corporate seals of the Companies have been affixed thereto this 26th day of September, 2016.



The Ohio Casualty Insurance Company
Liberty Mutual Insurance Company
West American Insurance Company

By: David M. Carey
David M. Carey, Assistant Secretary

STATE OF PENNSYLVANIA ss
COUNTY OF MONTGOMERY

On this 26th day of September, 2016, before me personally appeared David M. Carey, who acknowledged himself to be the Assistant Secretary of Liberty Mutual Insurance Company, The Ohio Casualty Company, and West American Insurance Company, and that he, as such, being authorized so to do, execute the foregoing instrument for the purposes therein contained by signing on behalf of the corporations by himself as a duly authorized officer.

IN WITNESS WHEREOF, I have hereunto subscribed my name and affixed my notarial seal at King of Prussia, Pennsylvania, on the day and year first above written.



COMMONWEALTH OF PENNSYLVANIA
Notarial Seal
Teresa Pastella, Notary Public
Upper Merion Twp., Montgomery County
My Commission Expires March 28, 2017
Member, Pennsylvania Association of Notaries

By: Teresa Pastella
Teresa Pastella, Notary Public

This Power of Attorney is made and executed pursuant to and by authority of the following By-laws and Authorizations of The Ohio Casualty Insurance Company, Liberty Mutual Insurance Company, and West American Insurance Company which resolutions are now in full force and effect reading as follows:

ARTICLE IV – OFFICERS – Section 12, Power of Attorney. Any officer or other official of the Corporation authorized for that purpose in writing by the Chairman or the President, and subject to such limitation as the Chairman or the President may prescribe, shall appoint such attorneys-in-fact, as may be necessary to act in behalf of the Corporation to make, execute, seal, acknowledge and deliver as surety any and all undertakings, bonds, recognizances and other surety obligations. Such attorneys-in-fact, subject to the limitations set forth in their respective powers of attorney, shall have full power to bind the Corporation by their signature and execution of any such instruments and to attach thereto the seal of the Corporation. When so executed, such instruments shall be as binding as if signed by the President and attested to by the Secretary. Any power or authority granted to any representative or attorney-in-fact under the provisions of this article may be revoked at any time by the Board, the Chairman, the President or by the officer or officers granting such power or authority.

ARTICLE XIII – Execution of Contracts – SECTION 5, Surety Bonds and Undertakings. Any officer of the Company authorized for that purpose in writing by the chairman or the president, and subject to such limitations as the chairman or the president may prescribe, shall appoint such attorneys-in-fact, as may be necessary to act in behalf of the Company to make, execute, seal, acknowledge and deliver as surety any and all undertakings, bonds, recognizances and other surety obligations. Such attorneys-in-fact subject to the limitations set forth in their respective powers of attorney, shall have full power to bind the Company by their signature and execution of any such instruments and to attach thereto the seal of the Company. When so executed such instruments shall be as binding as if signed by the president and attested by the secretary.

Certificate of Designation – The President of the Company, acting pursuant to the Bylaws of the Company, authorizes David M. Carey, Assistant Secretary to appoint such attorneys-in-fact as may be necessary to act on behalf of the Company to make, execute, seal, acknowledge and deliver as surety any and all undertakings, bonds, recognizances and other surety obligations.

Authorization – By unanimous consent of the Company's Board of Directors, the Company consents that facsimile or mechanically reproduced signature of any assistant secretary of the Company, wherever appearing upon a certified copy of any power of attorney issued by the Company in connection with surety bonds, shall be valid and binding upon the Company with the same force and effect as though manually affixed.

I, Renee C. Llewellyn, the undersigned, Assistant Secretary, The Ohio Casualty Insurance Company, Liberty Mutual Insurance Company, and West American Insurance Company do hereby certify that the original power of attorney of which the foregoing is a full, true and correct copy of the Power of Attorney executed by said Companies, is in full force and effect and has not been revoked.

IN TESTIMONY WHEREOF, I have hereunto set my hand and affixed the seals of said Companies this 4th day of January, 2017.



By: Renee C. Llewellyn
Renee C. Llewellyn, Assistant Secretary

**COMMONWEALTH OF VIRGINIA
DEPARTMENT OF TRANSPORTATION**

PROJECT: **0095-111-278, P101, R201, C501**

FHWA: **OC-095-2(535)**

This form must be completed, signed and returned with bid; and failure to do so may result in the rejection of your bid. **THE CONTRACTOR SHALL AFFIRM THE FOLLOWING STATEMENT EITHER BY SIGNING THE AFFIDAVIT AND HAVING IT NOTARIZED OR BY SIGNING THE UNSWORN DECLARATION UNDER PENALTY OF PERJURY UNDER THE LAWS OF THE UNITED STATES. A SEPARATE FORM MUST BE SUBMITTED BY EACH PRINCIPAL OF A JOINT VENTURE BID.**

STATEMENT. In preparation and submission of this bid, I, the firm, corporation or officers, agents or employees thereof did not, either directly or indirectly, enter into any combination or arrangement with any persons, firm or corporation or enter into any agreement, participate in any collusion, or otherwise take any action in the restraint of free, competitive bidding in violation of the Sherman Act (15 U.S.C. Section 1) or Article 1.1 or Chapter 12 of Title 18.2 (Virginia Governmental Frauds Act), Sections 59.1-9.1 through 59.1-9.17 or Sections 59.1-68.6 through 59.1-68.8 of the Code of Virginia.

AFFIDAVIT

The undersigned is duly authorized by the bidder to make the foregoing statement to be filed with bids submitted on behalf of the bidder for contracts to be let by the Commonwealth Transportation Board.

Signed at James City County, Virginia, this 21 day of November, 20 16
County (City), STATE

Branscome Incorporated By: [Signature]
(Name of Firm) (Signature) Title (print)

STATE of Virginia COUNTY (CITY) of James City County
To-wit:

I Janine Sabo, a Notary Public in and for the State and County(City) aforesaid, hereby certify that this day Stuart Patterson

personally appeared before me and made oath that he is duly authorized to make the above statements and that such statements are true and correct.

Subscribed and sworn to before me this 21 day of November, 20 16
[Signature] My Commission expires 11/30/2020

**OR
UNSWORN DECLARATION**

The undersigned is duly authorized by the bidder to make the foregoing statement to be filed with bids submitted on behalf of the bidder for contracts to be let by the Commonwealth Transportation Board.

Signed at _____, this _____ day of _____, 20 _____
County (City), STATE

By: _____
(Name of Firm) (Signature) Title (print)



**COMMONWEALTH OF VIRGINIA
DEPARTMENT OF TRANSPORTATION
AFFIDAVIT**

PROJECT: 0095-111-278, P101, R201, C501

FHWA: OC-095-2(535)

This form must be completed, signed, notarized and returned with bid; and failure to do so, may result in the rejection of your bid. A separate form must be submitted by each principal of a joint venture bid.

1. I, the firm, corporation or officers, agents or employees thereof have neither directly nor indirectly entered into any combination or arrangement with any person, firm or corporation or entered into any agreement, participated in any collusion, or otherwise taken any action in restraint of free competitive bidding in connection with such contract, the effect of which is to prevent competition or increase the cost of construction or maintenance of roads or bridges.

During the preceding twelve months, I (we) have been a member of the following Highway Contractor's Associations, as defined in Section 33.1-336 of the Code of Virginia (1970). (If none, so state).

NAME	Location of Principal Office
_____	_____
_____	_____
_____	_____

2. I (we) have _____, have not _____, participated in a previous contract or subcontract subject to the equal opportunity clause, as required by Executive Orders 10925, 11114, or 11246, and that I/We have _____, have not _____, filed with the joint Reporting Committee, the Director of the Office of Federal Contract Compliance, a Federal Government contracting or administering agency, or the former President's Committee on Equal Employment Opportunity, all reports due under the applicable filing requirements.

Note: The above certification is required by the Equal Employment Opportunity Regulations of the Secretary of Labor [41 CFR 60-1.7(b)(1)], and must be submitted by bidders and proposed subcontractors only in connection with contracts and subcontracts which are subject to the equal opportunity clause. Contracts and subcontracts which are exempt from the equal opportunity clause are set forth in 41 CFR 60-1.5. (Generally only contract or subcontracts of \$10,000 or under are exempt.)

Currently, Standard Form 100 (EEO-1) is the only report required by the Executive Orders or their implementing regulations.

Proposed prime contractors and subcontractors who have participated in a previous contract or subcontract subject to the Executive Orders and have not filed the required reports should note that 41 CFR 60-1.7(b) (1) prevents the award of contract and subcontract unless such contractor submits a report covering the delinquent period or such other period specified by the Federal Highway Administration or by the Director, Office of Federal Contract Compliance, U.S. Department of Labor.

(Continued)

ORDER NO.:
CONTRACT ID. NO.:

Form C-105
page 2

3. The bidder certifies to the best of its knowledge and belief, that it and its principals:
- (a) Are not presently debarred, suspended, proposed for debarment, declared ineligible or voluntarily excluded from covered transactions by any Federal department or agency;
 - (b) Have not within a three year period preceding this proposal been convicted of or had a civil judgement rendered against them for commission of fraud or a criminal offence in connection with obtaining, attempting to obtain, or performing a public (Federal, State or local) transaction or contract under a public transaction; violation of Federal or State antitrust statutes or commission of embezzlement, theft, forgery, bribery, falsification or destruction of records, making false statements, or receiving stolen property;
 - (c) Are not presently indicted for or otherwise criminally or civilly charged by a governmental entity (Federal, State or local) with commission of any of the offenses enumerated above; and
 - (d) Where the bidders is unable to certify to any of the statements in this certification, the bidder shall show an explanation below.

Explanations will not necessarily result in denial of award, but will be considered in determining bidder responsibility. For any explanation noted, indicate below to whom it applies, initiating agency, and dates of action. Providing false information may result in federal criminal prosecution or administration sanctions. The bidder shall provide immediate written notice to the Department if at any time the bidder learns that its certification was erroneous when submitted or has become erroneous by reason of change circumstances.

The undersigned is duly authorized by the bidder to make the foregoing statements to be filed with bids submitted on behalf of the bidder for contracts to be let by the Commonwealth Transportation Board.

Signed at James City County, Virginia, this 21 day of November, 20 16
County (City), STATE

Branscome Incorporated By: [Signature] [Print Name]
(Name of Firm) (Signature) Title (print)

STATE of Virginia COUNTY (CITY) of James City County

To-wit: I Janine Sabo, a Notary Public in and for the State and County(City) aforesaid, hereby certify that this day Stuart Patterson

personally appeared before me and made oath that he is duly authorized to make the above statements and that such statements are true and correct.

Subscribed and sworn to before me this 21 day of November, 20 16
[Signature] My Commission expires 11/30/2020

Notary Public



